INSWORKE TIDE MILL
MILLBROOK, CORNWALL

Archaeological Report
Building Record
and
Interpretation of the Mill



CYNTHIA GASKELL BROWN
and
MARTIN WATTS
with
CARL NEWTON

2011

This Archaeological Report, Building Record & Interpretation of Insworke Tide Mill, Millbrook,
Cornwall

was commissioned by

Mr Darren Newton, Multimarine Ltd, Foss Quay, Millbrook, PL10 1EN as a part requirement for
Planning Permission from Cornwall Council ref 09/01932/Full.

It was carried out by Cynthia Gaskell Brown, MA, AMA, FSA, Millbrook, Cornwall
(cgbrown@cgb.eclipse.co.uk)

and

Martin Watts, Cullompton, Devon (martin.watts@virgin.net)

with

Carl Newton, Concept Design, Modbury, Devon (Carl@C2-concept.com)

October 2011

NOTE ON PROJECT ARCHIVE

The project's documentary, photographic and drawn archive is deposited with Cornwall Record
Office, Truro. The contents of the archive are:

Project files containing site records, field drawings, notes and black and white films.

Indexed Digital photograph files on CDs.

A hard copy and digital copy of the report and indexes.

Hard copies and digital copies of the report, drawings and photographs are also deposited with
the Historic Environment Record, Cornwall Council, Truro; The Courtney Library, Royal Institu-
tion of Cornwall, Truro; Torpoint Library and Plymouth Library.

CONTENTS

Note on <u>Project Archive</u>	2
<u>Location Map 1. Plymouth and Millbrook</u>	6
<u>Location Map 2. Insworke Mill and Millbrook Lake</u>	6
<u>Summary</u>	7
<u>1. INTRODUCTION</u>	8
<u>1.1 General description</u>	8
<u>1.2 Special Circumstances</u>	8
<u>1.3 Recording Methods</u>	8
<u>2. HOW THE TIDE MILL WORKED</u>	9
<u>3. RESOURCES</u>	11
<u>3.1 Maps</u>	11
<u>3.2 Date Stones</u>	13
<u>3.3 Tree Ring Dates</u>	15
<u>3.4 Owners and Millers</u>	15
<u>3.4.1 Advertisement 1772</u>	15
<u>3.4.2 Agreement to rebuild 1795</u>	15
<u>3.4.3 Valuation 1809</u>	17
<u>3.4.4 Nineteenth century leases</u>	17
<u>3.4.5 Transcript of Sale of Machinery 1838</u>	18
<u>3.5 Postcards and Historic Photographs</u>	21
<u>3.6 Published Accounts</u>	24
<u>4. THE MILL BUILDING</u>	25
<u>EAST ELEVATION</u>	27
<u>WEST ELEVATION</u>	28
<u>NORTH AND SOUTH ELEVATIONS</u>	29
<u>GROUND PLAN</u>	30
<u>5. EXCAVATIONS</u>	31
<u>5.1 Area A Ground floor; entrance</u>	31
<u>5.2 Area C: Ground Floor and Basement: evaluation trench and selective clearance of main mill</u>	31
<u>5.3 Excavation on the line of the Mill Pool wall</u>	33
<u>5.4 Excavation outside the west wall</u>	34
<u>5.5 The Finds</u>	35
<u>5.5.1 Iron</u>	35
<u>5.5.2 Pottery and Glass</u>	37
<u>5.5.4 Stone: 16th century shaped granite</u>	41
<u>5.5.5 Stone: Dressed granite slabs</u>	42
<u>5.5.6 Stone: Millstones and Bearing block</u>	42
<u>6. MILLSTONES CATALOGUE</u>	44
<u>6.1 Millstones Discussion</u>	45

<u>7. BUILDING RECORD</u>	<u>48</u>
<u>7.1 Phase 1: 16th century</u>	<u>48</u>
<u>7.1.1 The Basement: Exterior East Wall</u>	<u>48</u>
<u>7.1.2 The Basement: Exterior West wall</u>	<u>49</u>
<u>7.1.3 Basement Interior</u>	<u>51</u>
<u>7.2 Phase 2: Late 18th century/ early 19th century</u>	<u>56</u>
<u>7.2.1 Ground Floor</u>	<u>57</u>
<u>7.2.2 First Floor Beams</u>	<u>59</u>
<u>7.2.3 The First Floor and connections to the Extension</u>	<u>62</u>
<u>7.2.4 The Roof timbers</u>	<u>63</u>
<u>7.3 Phase 3: 19th century</u>	<u>64</u>
<u>7.3.1 Sluice Channel S5.</u>	<u>64</u>
<u>7.3.2 Extension building.</u>	<u>64</u>
<u>7.4 Phase 4a: 20th century</u>	<u>67</u>
<u>7.5 Phase 4b: 20th century</u>	<u>68</u>
<u>7.6 Phase 5: 21st century</u>	<u>70</u>
<u>8. DISCUSSION & INTERPRETATION of Insworke Mill by Martin Watts</u>	<u>71</u>
<u>8.1 Introduction</u>	<u>71</u>
<u>8.2 Tide mill operation</u>	<u>71</u>
<u>8.3 Technical background: review of published sources</u>	<u>72</u>
<u>8.4 Development of Mill Layout</u>	<u>73</u>
<u>8.4.1 16th Century</u>	<u>73</u>
<u>8.4.2 18th and 19th centuries</u>	<u>73</u>
<u>8.4.3 20th century</u>	<u>75</u>
<u>8.5 Ancillary machinery</u>	<u>76</u>
<u>8.6 Acknowledgements by Martin Watts</u>	<u>76</u>
<u>9. BIBLIOGRAPHY</u>	<u>81</u>
<u>10. ACKNOWLEDGEMENTS by Cynthia Gaskell Brown</u>	<u>82</u>
<u>11. DOCUMENTARY RESOURCES</u>	<u>83</u>
<u>12. APPENDICES</u>	<u>84</u>
<u>12.1 Trefusis Family</u>	<u>84</u>
<u>12.2 Agreement 1795</u>	<u>85</u>
<u>12.3 Estimate for New Mill work c.1800</u>	<u>87</u>
<u>12.4 Plan of Mill with dimensions c.1800 Insworke Document. DRO; 69M/Box 88/11</u>	<u>89</u>
<u>13. TREE RING REPORT by ANDY MOIR</u>	<u>90</u>
<u>14. DRAWINGS: ELEVATIONS, SECTIONS and PLANS</u>	<u>09</u>
<u>14.1 Feature Codes</u>	<u>09</u>
<u>14.2 Colour Codes</u>	<u>109</u>
<u>14.3 North and South elevations</u>	<u>110</u>
<u>14.4 East Elevation</u>	<u>111</u>
<u>14.5 West Elevation</u>	<u>112</u>
<u>14.6 Internal Elevation east wall</u>	<u>113</u>
<u>14.7 Section looking west</u>	<u>115</u>
<u>14.8 Sections B-B and C-C</u>	<u>117</u>
<u>14.8 Section D-D</u>	<u>118</u>

RAME HISTORY GROUP 2017

<u>14.10 Section E-E and Elevation G-G</u>	<u>119</u>
<u>14.11 Elevations H-H and F-F</u>	<u>120</u>
<u>14.12 Ground Floor Plan</u>	<u>121</u>
<u>14.13 Basement Floor Plan</u>	<u>122</u>
<u>14.14 First Floor Plan</u>	<u>123</u>
<u>14.15 Second Floor Plan</u>	<u>124</u>
<u>14.16 Roof Plan</u>	<u>125</u>
<u>15. ARCHAEOLOGICAL DRAWINGS</u>	<u>126</u>
<u>15.1 Basement Section across Sluice S4 looking north</u>	<u>126</u>
<u>15.2 Basement Plan of Sluice S4</u>	<u>126</u>
<u>15.4 Basement Elevation of Sluice S2 and S5</u>	<u>127</u>
<u>15.5 Ground Floor Joists and Basement Sluices</u>	<u>128</u>
<u>15.6 Beams 1 and 2</u>	<u>129</u>
<u>15.7 Beams 3 and 4</u>	<u>130</u>
<u>15.8 Beams 5 and 6</u>	<u>131</u>
<u>15.9 Beam 7</u>	<u>132</u>
<u>16. BRIEF FOR ISTAR C BUILDING & ARCHAEOLOGICAL RECORDING</u>	<u>133</u>
<u>17. WRITTEN SCHEME OF INVESTIGATION</u>	<u>139</u>
<u>18. PROJECT BACKGROUND, AIMS, DESK TOP ASSESSMENT, METHODS</u>	<u>143</u>
<u>19. ARCHAEOLOGICAL CONTEXT LIST</u>	<u>146</u>
<u>20. BUILDING FEATURES CONTEXT LIST</u>	<u>147</u>

RAME HISTORY GROUP 2017

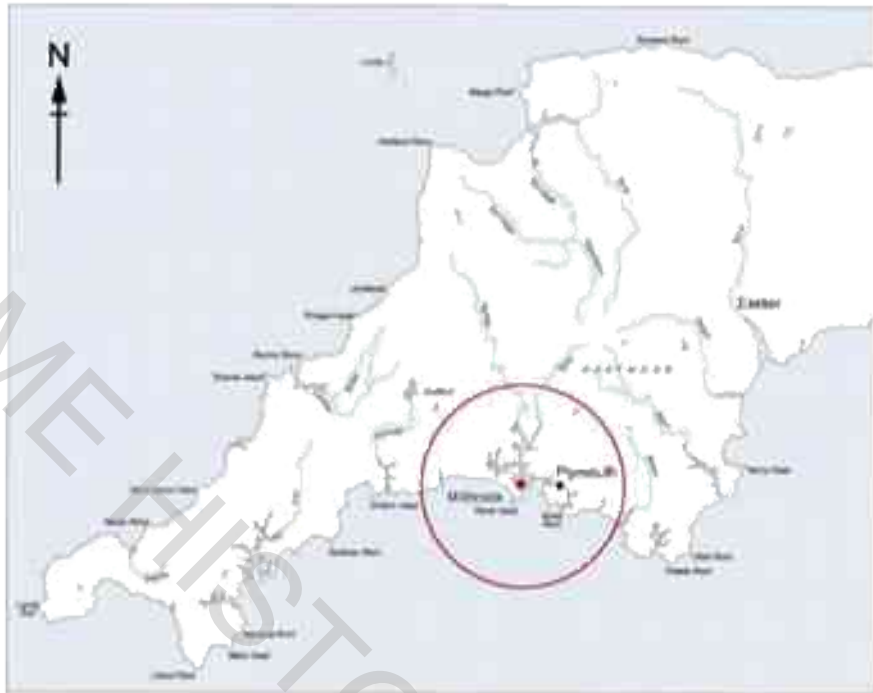

LOCATION MAP 1. PLYMOUTH AND MILLBROOK

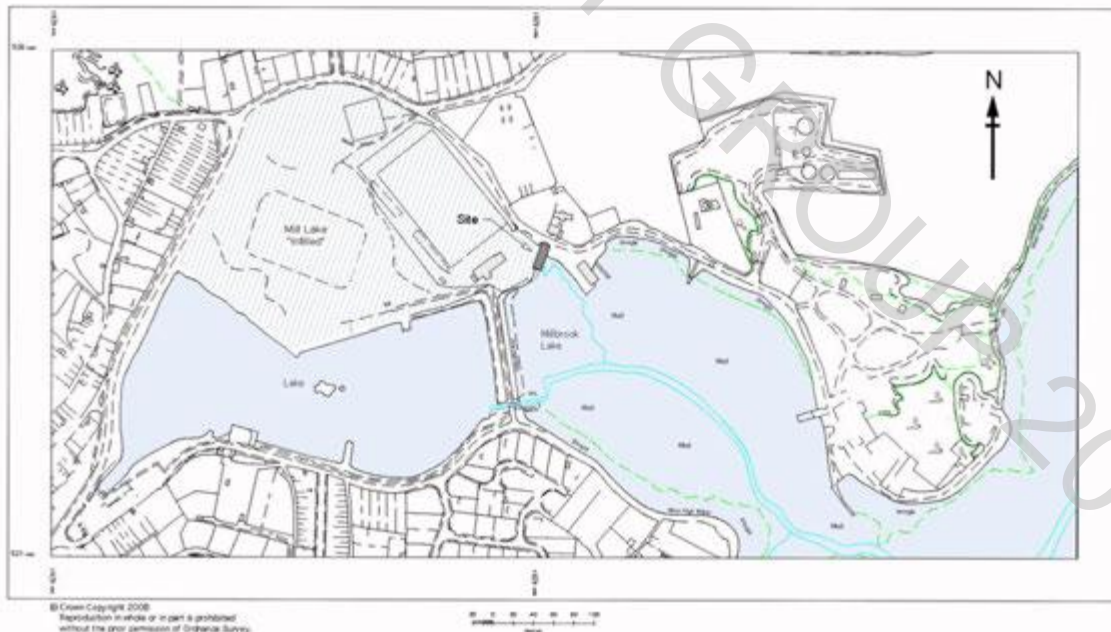

LOCATION MAP 2. INSWORKE MILL AND MILLBROOK LAKE

SUMMARY

Archaeological investigation and building recording was undertaken at Insworke Tide Mill, Millbrook, Cornwall (SX42899 52440) in 2010-11 before its conversion to a flat and offices and the partial rebuilding of the adjoining Mill Pool wall. No machinery survived in the mill. Two date stones, of 1598 and 1861, are built into the north wall of the mill. Evidence of four sluices or water channels integral to the original walls survive in the 16th century Basement. Three of these were narrow and could have held waterwheels in the late 16th century each driving a single pair of millstones. The wider stone arched opening was probably originally a spillway.

The mill was rebuilt on top of the Basement in 1800-1801. This dating was established by a tree ring date from a first floor beam which gave a felling date for the winter of 1799-1800. This was confirmed by the documentary evidence of an 1795 *Agreement to Rebuild* and an 1800-1801 *Estimate of Costs* for the repair and rebuilding of the mill machinery. This last document shows that in 1800 there were three waterwheels, one driving two pairs of French stones and grinding wheat for flour; a second for the barley mill, producing animal feed or possibly malt for brewing; and a third wheel which drove the sack hoist and the bolting mills which separated fine flour from meal.

In the mid 19th century phase the 16th century sluice opening at the southern-most end of the mill was almost obliterated and replaced by a wider arch and water channel. Larger diameter waterwheels used the two bigger sluice channels and are recorded in the 20th century as each driving two pairs of millstones. Inside, the millstones were probably set up on hurst frames standing on the ground floor, not at first floor level. This uncommon arrangement was paralleled at nearby Antony and Wacker Tide Mills in Cornwall and at Beaulieu Mill, Hampshire.

Eight discarded millstones and millstone fragments found on site date from the 18th and 19th century. Particularly interesting are two granite centres, of Cornish type, from composite millstones which would have used imported French burr stone for the grinding faces. Fragments of worn out burr millstones are built into the upper walls of the exterior of the 1800 mill.

An Extension added to the north end of the mill may be dated by the 1861 stone. Milling had stopped by 1914 and the machinery was removed in the late 1930s or 1940s. At that time the sluice openings were in partly blocked up with reused 16th and 18th century dressed stones. The Basement was deliberately filled up to ground floor level with clinker waste from the nearby brickworks and floored over with bricks and later with concrete. In the 20th century the building was used as a base for the Millbrook Steamboat Company, for selling coal and fertilizer and latterly as a boat repair shed. Minor adaptations and repairs to the windows, doors and roof date from the later 20th century.

Cynthia Gaskell Brown and Martin Watts

October 2011

1. INTRODUCTION

Insworke Tide Mill stands on the north shore of Millbrook Lake, Maker Parish, Cornwall, (SX42899 52440). It is a Listed Grade II historic building with date stones for 1598 and 1861 on the north gable. An archaeological and historical assessment was carried out in 2008 by Cynthia Gaskell Brown in support of a planning application (Cornwall Council ref 09/01932/Full) on behalf of Mr Darren Newton, Multimarine Ltd. This was for conversion of the building to a flat and offices and the creation of a quay on part of the former Mill Pool. Planning approval was given in 2010 subject to the programme of archaeological and building recording which is reported here (See Sections 16-18 for background and technical documents).

1.1 General description

Built as a tide powered corn mill in 1598 Insworke Mill produced flour and grist meal for cattle feed for over three centuries. It was rebuilt in 1800 -1801. In the late nineteenth century the millers diversified and sold coal, fertilizer and grain. Milling stopped around 1914 and the building was partly converted for use as a coal store and used as the base for the Millbrook Steamboat Company. In recent years it became a boat repair shed.

The adjoining 7 hectare (16 acre) Tidal Mill Pool was bounded by a wall with two sets of sluice gates. It was infilled as a rubbish tip by Caradon District Council in the 1960s. It is now a football field and recreation area which still retains the footprint of the Mill Pool.

The mill is stone built and by the early 20th century had a corrugated iron roof. The main building consists of two floors and a Loft and a Basement which contained the waterwheels and sluice gates. An Extension on the north side has two floors and a loft. No machinery survived.

1.2 Special Circumstances

The unsafe remains of temporary wooden flooring at first floor level, a staircase, and parts of two sack ramps survived until 2008. These were photographed and briefly recorded by Cynthia Gaskell Brown in 2008 and included on the full site survey drawings at 1:100 by Preston Engineering in August 2010. By late 2010 most of the internal features had been removed leaving only the timber roof trusses, first floor beams and the infilled basement covered by the concrete ground floor.

The stability of the building was of concern with rotting timber lintels over sluice arches and windows. The ends of the first floor beams also had rotted in the walls. The Basement is built on the creek bed and is affected by tides; at spring tides (twice monthly) the water rises to ground floor level inside the building and has badly eroded the foundations on the south west corner. These factors presented particular problems and limitations. For example block-work shoring was needed in some places before access could be gained to record information. Certain areas were only free of water for about two hours and each tide brought in a coating of silt which had to be cleaned before recording could continue. The recording project ran from November 2010 to June 2011.

1.3 Recording Methods

To provide machine access to the main part of the building (area C) the ground level in the Extension (area A) was partially lowered by hand and the internal door D3 was widened. The first floor beams (area C) were then taken down, placed on trestles and recorded. These were removed to store on the quay. Access to the roof trusses was then gained by scissor lift where two sample trusses were measured and the roof photographed.

In order to record and understand the structure of the Basement an evaluation trench was dug through the concrete ground floor. This then informed selective machine and hand digging adjacent to the sluice openings inside the Basement walls.

Trenches dug by machine outside the south wall and along the outer face of the west wall for a new quay wall and for drainage were monitored and limited recording was achieved. A drawn

RAME HISTORY GROUP 2017

and photographic record was made of both the building and the excavations and the Preston Engineering Survey was updated as appropriate

2. HOW THE TIDE MILL WORKED

The water wheels which powered Insworke Mill were beneath the ground floor of the building and the remains of five arches in the east wall of the Basement mark the sluice channels.

Water was impounded in a 16 acre Mill Pool to the west of the mill which was filled by the incoming tide. This was let in through sluice gates in the Pool wall. The positions of these sluice gates can be seen on the 1912 O.S plan (see Section 3.1). Once the Mill Pool was full and after the tide had ebbed a little, milling could begin. The miller expertly controlled the flow of water both into the pool and then under the waterwheels by means of sluice gates in the west wall of the mill building. On average no more than five hours of milling might be achieved on each tide. As tides moved through the day and month so did the millers' working hours.

The sluice gates and the Mill Pool wall needed careful attention and constant maintenance. Outflow from local streams and heavy rainfall caused fluctuations in the water levels of the Mill Pool and debris washed in by the tide or from the local fields and villages could block the sluices and affect the smooth running of the mill wheels.

The Insworke Mill Pool began to be filled in as a refuse dump from 1966 and has now been landscaped and is used for Millbrook Football Club pitch and other recreational activities.

The milling machinery has long since been removed but it would have been similar to that in the more commonplace corn mills which have the waterwheels outside the building powered by leats channelled from rivers. A good local working example is to be seen at Cotehele, St Dominic (National Trust). The big difference in the structure of tide mills is that the waterwheels were normally below the mill itself.

Pit wheels and gearing inside the mill were often partially enclosed behind wooden shutters and doors. The mills worked from top to bottom. Sacks of grain were brought to the mill and hoisted up the outside of the building to the top floor or Loft and stored. From there grain was passed through cleaning machines and then fed down through hoppers to the millstones on the floor below where it was ground. The flour or meal then went into a meal bin or direct to sacks. The Ground floor was normally the place where the flour and meal was bagged up, weighed and sold to customers.

In most tide mills, however, the waterwheels were in the Basement. The Ground floor gave access to the sluice gears which controlled water flow under the mill, the gearing, the main vertical shafts and spur wheels as well as to the waterwheels. In some cases the millstones were on a mezzanine floor or on a hurst structure on the ground floor. An example of this is Beaulieu Tide Mill and there is some evidence that at Insworke the stones were on a hurst structure on the ground floor. The possible evolution of the arrangements at Insworke are discussed in detail by Martin Watts in Section 8 below.

RAME HISTORY GROUP 2017

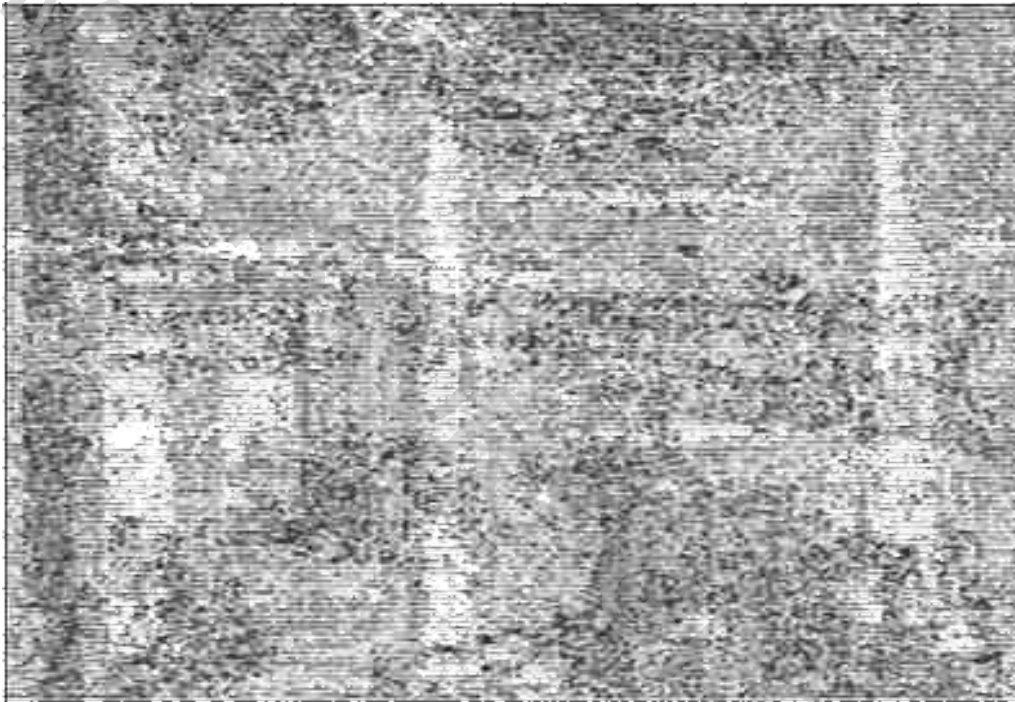

Engraving by Jan de Strada

An early seventeenth century German watermill on a river with the simplest kind of gearing. Note the sluice opening between the wheel arches. The picture shows all the busy elements of milling. In the foreground grain is being brought in on horseback with sacks being weighed to the left. Inside the building grain is poured into hoppers which feed onto the millstones. Waterwheels under the mill with lantern gears transfer power direct to the mill stones above.

Insworke Mill by the 18th century had much more complex and efficient gearing which is discussed below in Section 8.

3. RESOURCES

3.1 Maps



Board of Ordnance map by William Gardner 1784. British Museum MR1-1385 (Stuart 1991 no. 180.)
The oldest map showing the context of tide mill and its mill house in some detail dates from 1784.
Notice the Insworke peninsula with saltings to the north opening onto St Johns Lake.



The Manor Farm and the Chapel, which was licensed in 1331, show as a group of buildings around a court-yard to the north of the mill labelled Lower Incesworth. The Mill Pond wall is shown in red. To the east is Foss and at what is now called Southdown is the Kings Brewhouse. The Borough of Millbrook, which was created by the Champernowne family in 1319 lies to the west.

RAME HISTORY GROUP 2017

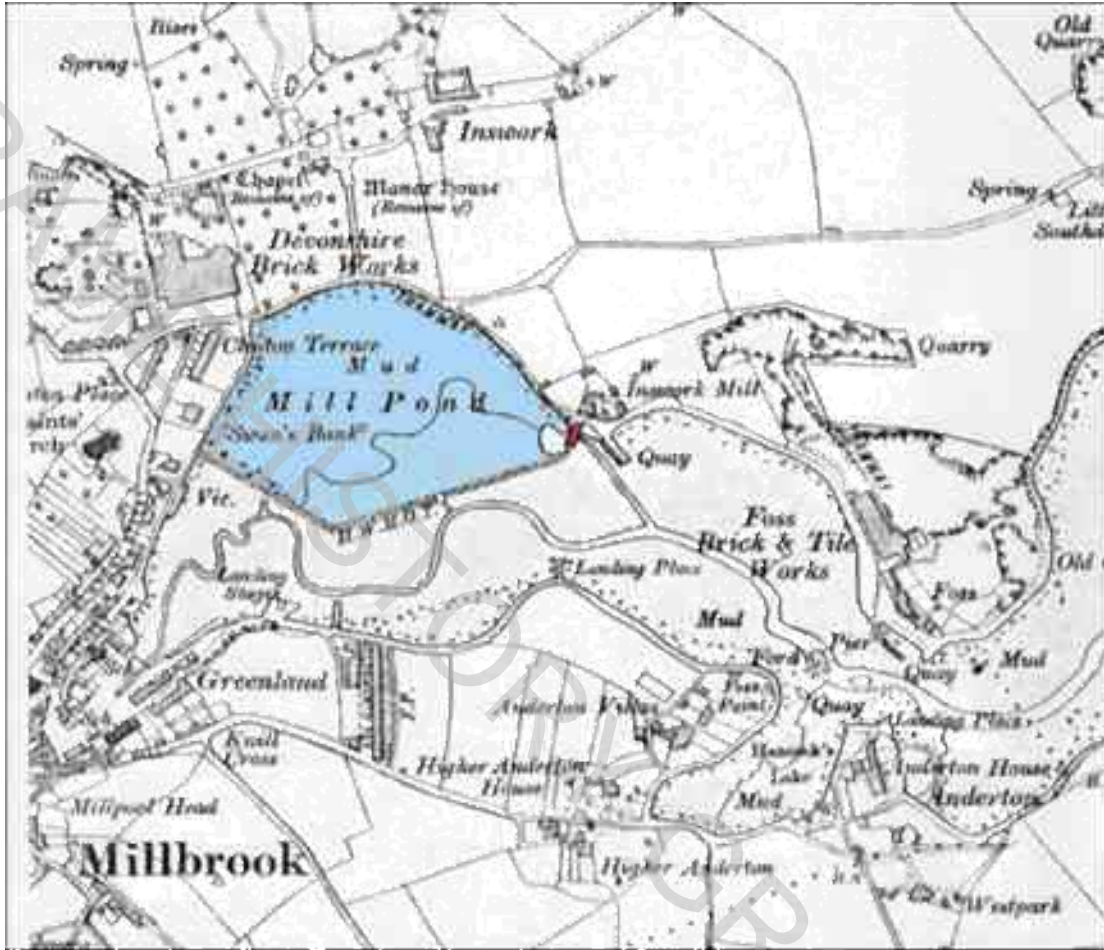

The 1912 Ordnance Survey plan is particularly helpful as it provides information about the then active local brickworks and tramways as well as the sluice gates to the Mill Pool. The advent of the 1914-18 war radically changed the local economy and led to the demise of the tide mill.

3.2 Date Stones

The two Date Stones built into the north wall of the mill have been variously recorded since 1936. The older date stone is carved in high relief out of sandstone with a robust cable moulding round the edge. The date in 16th century style lettering reads 1598 with a circular motif in the centre. This motif may represent a waterwheel as it does not have any obvious family or heraldic connection. The cable moulding is slightly damaged on the top and bottom edges doubtless caused when it was taken from its original position on the main mill wall. In the 1980s this stone was obscured by moss and lichens but has since been cleaned.

In August 2011 while reviewing photographs taken in 2008 it became clear that the date on the upper granite stone is **1861** not 1801, as had previously been thought. This was confirmed when scaffolding allowed close examination in September 2011.



The granite stone is flush with wall and the Roman lettering is carefully chiselled complete with serifs. It is however quite shallow and has been scoured clean at each end so removing parts of the inscription. In 1937 Rex Wailes recorded the stone as:-

REBUILT IN
L 1801 C

As the photographs show the date is actually 1861. Faint traces of the letter "C " to the right are perhaps still visible. However recently discovered notes by Rex Wailes which are discussed by Martin Watts in Section 8 below show that Wailes was not sure about the existence of the letter "L". The letter "C" may relate to the owner Lord Clinton. Earlier accounts of the mill which are quoted below all use the 1801 date, as did the Tree Ring report prepared in April 2011 . The documentary evidence discussed below shows that the mill was rebuilt in 1800 - 1801. It is possible that this date stone was altered later to adapt the O to a 6 if the Extension was built in 1861.

RAME HISTORY GROUP 2017



North Wall in 2008 with date stones below the window



East Wall in 2008 showing the Football club building to the left

3.3 Tree Ring Dates

Dates were obtained from two oak timbers (Section 13). Beam B6 from the first floor provided a felling date of winter 1799 – 1800. A sample from ground floor joist J4 gave felling date range that supported the more precise date from the first floor timber. Together with the documents discussed in Section 3.4 below these dates provide good evidence for a reconstruction phase in AD1800-1801.

3.4 Owners and Millers

In medieval times the manor of Insworke was owned by the Champernowne family. The manor passed through marriage to the Rolle family and then to Robert Walpole, 2nd Earl of Orford, the son of the British Prime Minister Robert Walpole. The Walpoles married into the Trefusis family of Cornwall who held the Barony of Clinton and Say (Lysons, 1814: Appendix 12.1). Insworke Manor and its mill was sold out of the Clinton Estates in the 20th century. Documentary material is available in Cornwall, Devon and Plymouth Record Offices but many Trefusis family papers are not available at present. No sixteenth century records relating to the mill have so far been located.

3.4.1 Advertisement 1772

Insworke Tide mill was the manorial mill. The Countess of Orford noted in the 1772 advertisement below was part of the Rolle family. In this 18th century advertisement a lease of fourteen or twenty one years for “ All those Salt Water Greist Mills called Inswork Mills”.

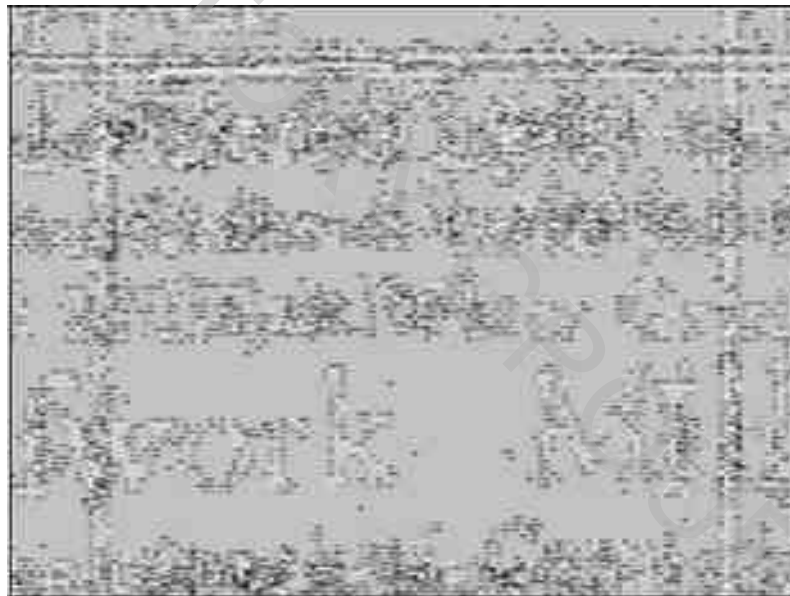

Inswork Mills advertised to let in the Sherborne Mercury of 6th January 1772

3.4.2 Agreement to rebuild 1795

It is not known who took the mill in 1772 but the next available document is an Agreement of 1795 between the Trustees of Lord Clinton (who was a minor at the time) and William Bickford, Miller (DRO:69M/Box15/15. See transcript in Appendix 12.2). Bickford had signed a lease on 25 March 1795 subject to the Mill and Dwelling house being first repaired by Lord Clinton. However this new agreement of 29th July states that:-

“Whereas upon carefully and minutely examining the condition of the said Mills & Mill-house they have both been found to be in such a State of general Dilapidation & decay that it is utterly impossible to repair the same with any advantage to the Landlord or

RAME HISTORY GROUP 2017

Tenant but the whole must be taken down & rebuilt And whereas the said Millhouse or Dwelling house at present stands so low that the same is frequently overflowed by more than two feet water in the ground floor to the great inconvenience & danger of the tenant & his Family."

The Agreement describes the Mills as:-

"All those corn or grist mills called Insworth Salt Water Grist Mills together with the Mill-house and Garden thereto belonging situate on the salt water adjoining the spot of ground where Millbrook Old Brewhouse formerly stood in the parish of Maker; and also the Fishing thereto belonging and all those two fields called Hillpark, containing by estimate seven acres one rood and two poles or thereabouts, and Hillgreen alias illgreen containing one acre and half and thirty four poles (more or less) then in the possession of the said Willm Bickford"

The miller would have normally paid a rent of £60 per annum for twenty one years and have been required to: -

"Repair, amend & keep in good repair Houses, Walls, Windows, Coverings, Doors ,Flood Gates, Flood Hatches, Wheels, Cogs, Rounds, Alter boards, Stirts, all Brass & Iron work & all & every the Gates, Barrs, Stiles Hedges, Ditches, Gutters, Fences"

However in view of the dilapidation it was agreed that:-

"Lord Clinton will cause the said Mills & Millhouse or Dwelling house to be new built & erected in a strong and substantial manner & with as much dispatch as may conveniently may be & that the said Dwelling house shall be built and placed in an higher & better situation than the site of the old Millhouse for the accommodation of the said William Bickford & his family".

William Bickford had to pay in advance for the rebuilding and the carriage of materials but this cost was to be repaid by Lord Clinton's agents or offset against the rent. Once the repairs and rebuilding was complete Bickford then had to pay a higher rent, presumably to represent the increased value of the Mill.

Despite saying the work should be done *"with as much dispatch as conveniently may be"* it seems no real action was taken for about five years. A small bundle of about nineteen notes, estimates and bills in the Rolle papers, labelled rather misleadingly "Kellow Mill and New Barn at Insworth" (DRO: Box88/11) date from 1798, 1800 and 1801. Here is the evidence that the Mill and Millhouse were being rebuilt at that time as well as the building of a new "Chall" or Barn with shippens and stables underneath it and repairs to the courtyard wall of the adjoining Insworth Barton Farm and conversion of the medieval Chapel to stables. The oldest paper in this bundle is a Proposal for building a new Barn dated 13 November 1798. It also includes scale plans of the Stables and Chall and of the Mill building (Appendix 12.4)

The most important item amongst these papers is headed *"At Insworth Mills An estimate for the New Mill work and the Repeating the Old Mill Work belonging to the Right Honourable Lord Clinton by Mr Denston* (Transcript in Appendix 12.3). This is a fully itemised list of the parts needed to rebuild and repair the mill including the main oak shaft to drive the two mills for £10.10.0 and repairing the barley mill water wheel for £3.3.0. The total price comes to £255.9.10

RAME HISTORY GROUP 2017

and is discussed below by Martin Watts in Section 8. This would have been worth around £8350 in 2005 (<http://www.nationalarchives.gov.uk/currency/>).

A reference to *Wm Denston* also occurs in a note dated 10 June 1800 where he “weighted the bark in Cumbletor Wood”; and in rough pencilled notes, presumably made on site by the agent and partly dated October 29th and 30th 1800, *Dunster* is mentioned as having enough trees for the mill wheels; and “Mr *Duster* the mill carpenter to deliver timber”. This documentary material fits neatly with the tree ring date of the winter of 1799/1800 for the felling of oaks that survived as beams and joists in the mill. These notes are mixed in with references to building the barn and court walls. A bill for day work at “Kellow Mills” dated March and April 1800 covers digging, clearing and building walls and totals £15.1.9. Further notes about work on the barn and chapel are dated May 1801.

3.4.3 Valuation 1809

Following the repairs and rebuilding we find a Valuation of the Manor dated 1809 which shows William Bickford as miller and John Avery as the farmer at Insworke Manor farm.

1809 Valuation of the Manor of Millbrook and Insworke for Lord Clinton
(*CRO Trefusis Papers X1147/1/10*) 2005 spending equivalent in brackets .

60. Insworke Manor farm Tenant John Avery	£ 16,212 . 0 . 0 (£550,566. 0)
65. Manor Mills Tenant William Bickford	£ 3522 . 0 . 0 (£120,000)
63. Messuage & limekiln at Foss Messuage & ropewalk at Foss Tenement at Anderton & ropewalk at Beales Quay Tenant Edward Chubb	£ 426 . 0 . 0 (£14,500)

3.4.4 Nineteenth century leases

Two leases of 1839 and 1852 examined in the West Devon record office were each for seven years and were with members of the Parson family (WDRO 68/20;6921). Continuity in milling families was usual because although the initial capital investment in building a mill and its machinery fell on the owner - and this might have been invested several centuries previously as can be seen at Insworke - it was the miller who had the responsibility for maintaining and repairing the mill equipment as the Agreement of 1795 shows.

The two 19th century leases are for the Messuage, the tide water grist mill called Insworke Mill, Maker, with the Quay and machinery and Two fields called the Meadow or Mill Green and the Mill Field or Kiln Park. They gave the miller the right to take timber – with permission – from Insworke Barton lands to repair the mill machinery and building.

In 1839 the new tenant is Lewis Parson of St Johns Mills - so the tenancy is being taken on by a local miller. The 1852 lease is with Mr Nicholas Parson. After this time John Parson and his family are listed in Census returns and Trade directories at the Insworke Mill until the early 20th century. By chance, folded within the 1852 lease, is a piece of paper which gives the name of the miller who held Insworke just before the Parson family first took it over in 1838. On this paper Mr Gorge Jak (*sic*) lists the moveable items in the mill which he is selling to Lewis Parson, together with hay and dung on the land which was leased with the mill, for £61.0.0. This was roughly the equivalent of a skilled craftsman’s wages for a year.

RAME HISTORY GROUP 2017

3.4.5 Transcript of Sale of Machinery 1838

Sale of machinery from Inswork Mill by Gorge Jak in 1838. Obverse of sheet of paper inside the 1852 lease with transcript. WDRO 68/21

I Mr Gorge Jak do hereby agree
to sell to Mr Lewis Parsons of St
Johns Mills all the Machinery Threshy
in sorted with the railing a crops
the field and the hay rick and the
heap of dung in the Court and the
dung that may made betwix this
and Christmas next for the Sum of
Sixty one Pounds by Mr Lewis
Parsons taking all the Refous upon
himself - Witness James Hill
Dated 16th Sept 1838 - Gorge Jak
Mr Gorge Jak Mark X
Settled by George Jak

" I Mr Gorge Jak do hereby agree to sell to Mr Lewis Parsons of St Johns Mills all the Machinery herby inserted with the railing across the field and the hay rick and the heap of dung in the Court and the dung that may made between this and Christmas next for the Sum of Sixty one pounds by Mr Lewis Parsons taking all the refous(?) upon himself Date 16th dated 18th Sepr 1838 Witness James Hill Gorge Jak "

Mr Gorge Jak mark X

Settled by George Jak

RAME HISTORY GROUP 2017

Reverse of paper inside lease of 1852 with transcript.

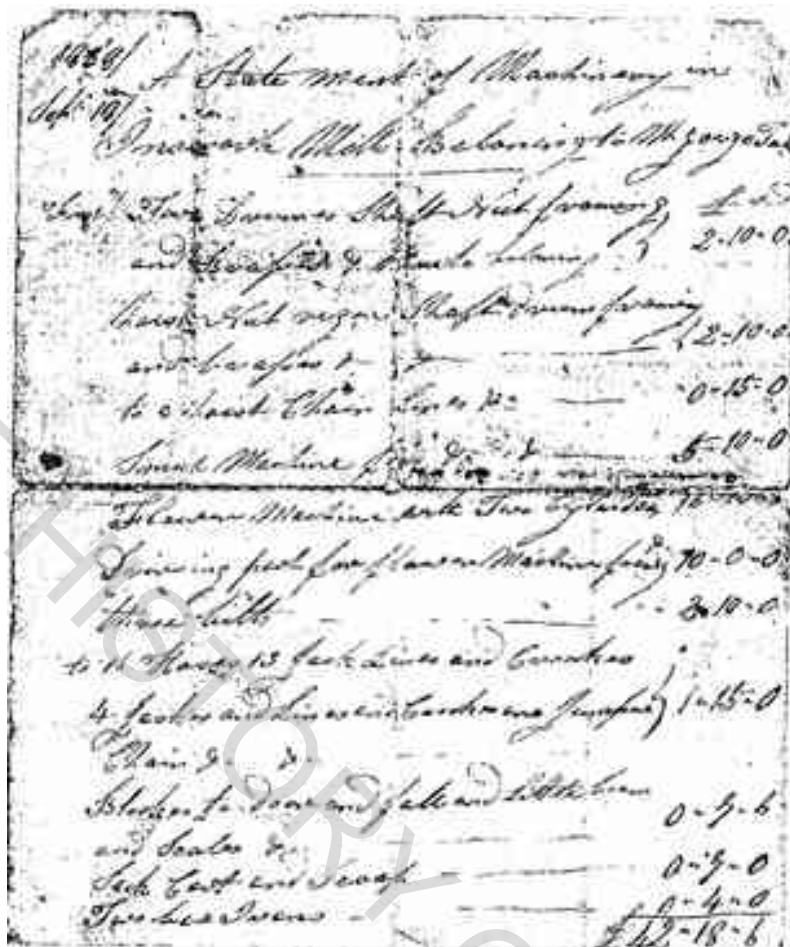

"1838

Sep^t 18

First/

A Statement of Machinery in

Insworke Mills belonging to Mr Gorge Jak

	£	s	d
Two Drumes Shaft Nut framing			
and Brasses & thereto belonging	2	10	0
Hoist nut riger Shaft drum framing			
and brasses & c	2	10	0
to a hoist chain lines & c	0	15	0
Smut Machine fan & c & c	5	10	0
Flower machine with Two Cylinders	16	10	0
Driveing post for flower machine framing & c	10	0	0
three bitts	2	10	0
to 16 Hoses 13 Jack Lines and Crookes			
4 Jacks and Lines and Crookes one Jumper	1	15	0
Chain & c & c			
Blockes to doore and fall and Little beam			
and Scales & c	0	7	6
Sack Cart and Scoap	0	7	0
Two bar Irons	0	4	0
	£42	18	6

£42 18 6 "

RAME HISTORY GROUP 2017

Notes by Martin Watts

<i>drumes</i>	Wide pulleys for belt drives
<i>nut</i>	Pinion, small gear
<i>brasses</i>	Bearings
<i>rigger</i>	Rigger = pulley
<i>lines</i>	Presumably cords for operating hoist chain
<i>flower machine</i>	For dressing flour
<i>driveing post</i>	? Shaft
<i>bitts</i>	?
<i>hoses</i>	?
<i>jack lines & crookes</i>	Cords for hanging bent timber pieces for holding sacks open
<i>jumper</i>	Reciprocating sieve for sifting, usually direct from meal spout
<i>chain</i>	In this connection, for suspending jumper
<i>blockes</i> ?	
<i>little beam & scales</i>	? Beam scales for weighting sacks
<i>sack cart</i>	Sack barrow
<i>scoap</i>	?Scoop (dialect?)
<i>bar irons</i>	Crowbars for moving millstones, adjusting machinery

All the items appear to represent the lighter, more portable end of milling equipment, presumably installed and owned by the tenant rather than the landlord.

3.5 Postcards and Historic Photographs

Some nineteenth and twentieth century postcards and photographs also provide evidence for the context and structure of the mill. Postcards are difficult to date unless they have been used. Approximate dates have been offered here.



c.1897. Postcard view looking west over Millbrook Lake. Insworke Mill and its Mill pond are in the middle distance, towards the right of the picture. Anderton Quay and shipyard with various barges moored alongside is in the foreground.

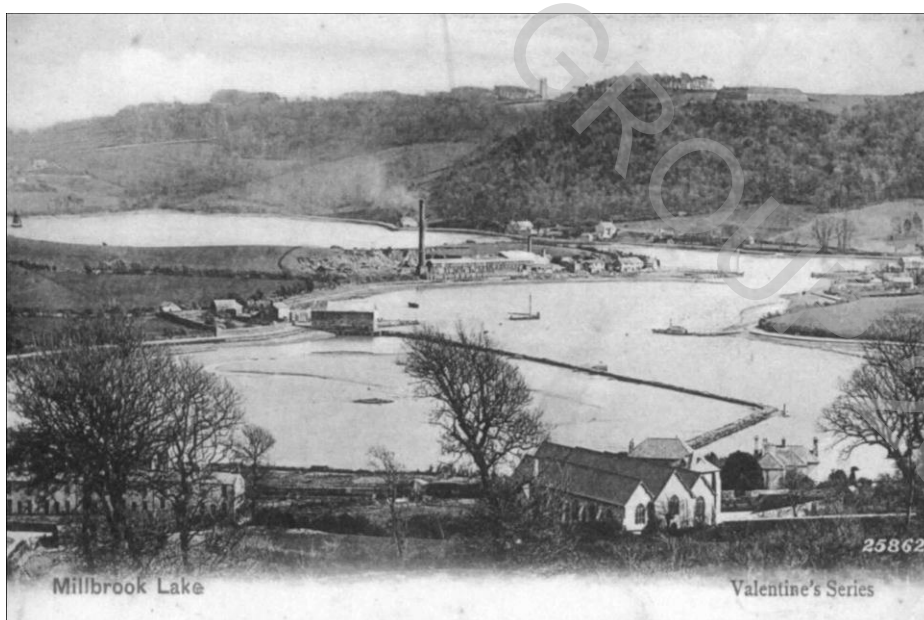

c. 1904. Postcard view looking east over Millbrook Lake. Millbrook Church in the foreground was completed in 1895. This gives a rare view of the Mill Pool and the Mill building from the west. Faint indications of the sluice channels beneath a wooden staging or stone platform on the lower part of the mill wall can just be made out. Foss Brickworks chimney lies just beyond. This brickworks was begun c. 1870. Maker Church can be seen on the skyline. Number 5 Redoubt built in 1783 above Clarrick Woods is to the right of Maker Church.

RAME HISTORY GROUP 2017



c.1911. Postcard view of Millbrook Steamers at Lower Pier on Millbrook Lake. Insworke Mill can be seen in the background. The paddle steamer "Lady Ernestine" is tied against the pier with one of the Cremyll ferry boats landing people on the beach. "Lady Ernestine" was taken off the Millbrook Lake route in 1911 and broken up in 1925.



Jack Kingston/ Alan Kittridge

This detail from the above postcard shows the Mill with a slate roof and a chimney stack, parts of the Mill Pool wall with its sluice opening next to the Mill building and the Mill House behind. Tamar barges are alongside John Parsons' quay.

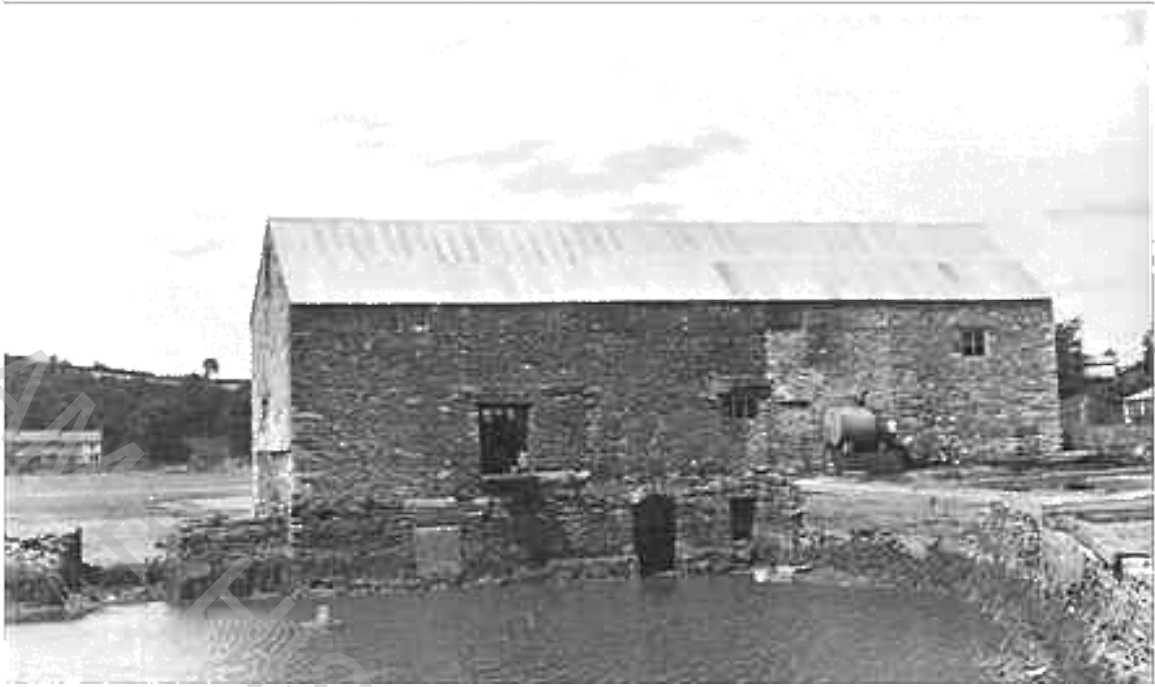

Rex Wailes/Alan Stoyel

1937. Between 1936 and 1938 the engineer Rex Wailes visited and described twenty three tide mills in England and Wales. These two photographs of Insworke Mill are amongst his papers and show both east and west sides of the building and the sluice opening through the Mill Pool wall. The building by now has a corrugated iron roof, no chimney stack and the sluice openings on the east face are blocked up. On the back (west face, below) a stone platform has only two gaps which would have allowed water through the building. The strange colour variations on the stone work do not correspond to building phases; however as the walls are free of vegetation and the quay is clear it is possible that cleaning up work, such as raking out the joints, was in progress.



Rex Wailes/Alan Stoyel

3.6 Published Accounts

Rex Wailes, a noted engineer and expert on mills who visited Insworke Mill in July 1937 (Wailes, 1938-39) provides this account:-

“Millbrook Mill on Millbrook Lake ceased working before the war of 1914. It had two wheels each driving two pairs of stones and bears on a stone the date 15+18 (sic) with a cable moulding surrounding, and above is another: REBUILT IN L 1801 C (sic). It is now a coal store and its stone walls are roofed with corrugated iron”

An oral history account of the mill was collected in 1963 as part of an Exeter University history group study (Harris, 1963):-

“The local corn mill at Millbrook was an “undergrist” mill worked by the tide. At one time it had four waterwheels but three are remembered, two large ones about fourteen feet across and one small one for auxiliary lifting to the second or third storey. It belonged to Mr Parson and was last worked at the turn of the century (19th/20th) by Mr Harris.....”

English Heritage Listed Building Description:

“Millbrook Mill: Tide Mill. Dated 1598, rebuilt in 1801 with some later alterations. Sandstone rubble with granite and sandstone quoins; corrugated iron roof. The east front has the sluice arches, the mill pond was formerly to the rear, now infilled. In the early C19 an addition at the same height was made to the right end, with straight joint between. 2 storeys with water channels below and loft over. Front has 2 sluice arches with round heads, one to left blocked, further opening to the right with flat granite lintel. At ground floor level (over water) a door with timber lintel, and C 20 window to right; 3 C20 windows under eaves. C19 addition to right with C20 window at first floor. Right gable end has cart entry with timber lintel internally, 6- pane light above; date stone with cable moulding. Left gable end has granite quoins, asbestos slate-hung at ground floor level and above, with C20 windows at ground floor and loft level. Rear 3 C20 windows at ground floor, the central one with cambered and chamfered lintel internally, 2 similar windows under eaves.

Interior. The roof is of the 1801 rebuilding with halved and crossed principal rafters pegged, with 2 rows of purlins and upper collars. At first floor, 7 heavy chamfered cross beams survive, 8 morticed and chamfered cross beams at roof level. The mill had 2 wheels each driving 2 pairs of stones. The sack hoist pulley at ground floor is the only remnant of the milling machinery. The mill is in a prominent position on Millbrook Lake.”

4. THE MILL BUILDING

Millbrook Lake is a tidal creek which runs into the south end of the River Tamar. The Borough of Millbrook was created in 1319 and in Medieval and Tudor times the area was involved in ship-building, fishing and agriculture. Eastwards across the Tamar from the creek is Plymouth Dockyard, founded in 1691. From the creek rapid access can be had by water to Plymouth Sound or up the Tamar valley. In the 19th century the local area was involved in a variety of industrial activities. The Devonshire Brickworks, Foss Brickworks and Southdown Brickworks used clay quarried on the north shore of Millbrook and dominated the area during the 19th and 20th centuries.

Insworke Tide Mill is a rectangular building which projects from the north shore of Millbrook Lake with its foundations on river silts. The original building was probably built in 1598 and rebuilt in 1801. An Extension was added to the north side of the mill at an unknown date in the 19th century.

The walls are random rubble using locally available slate-stones with dressed granite for sluice lintels and quoins. Fragments of French burr mill stones can be found in the east and north walls of the original building. The walls of the Extension are predominantly of blue elvan stones, the nearest source for this being Menheniot in south east Cornwall.

The mill has two floors with a loft and a basement which is regularly filled by the tide. Any subdivisions within the main mill were of timber and had been removed before the recording work began. The roof trusses and the first floor cross beams, a wooden stair in the north east corner and partial remains of a sack ramp on the north wall were the only remnants of the original internal arrangements. The ground floor of the Extension is divided by a stone wall into two spaces but first and upper floors were open. Access from the landward side is through doors in the north walls; a door in the east wall at ground floor level provided access from boats at high tide.

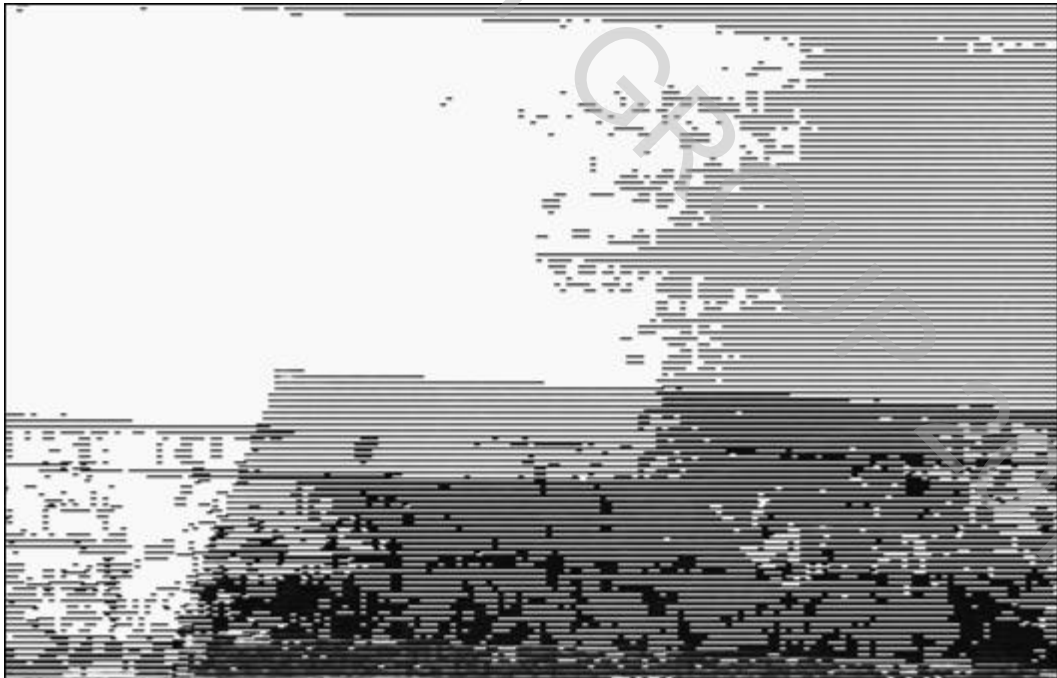

Julie Ellworthy

1970s. This photograph of the east wall shows alterations to the windows notably at the first floor south end which has been enlarged. The building and quay are overgrown with vegetation. The new Football Club building is visible at the left.

RAME HISTORY GROUP 2017



East face at mid-tide 2008



Date stones



East face 2008



West face 2011



East Face showing sluice openings



West face foundations and blocked sluices



East and north faces showing Extension



South face with slate hanging 2008



North face with date stones below window



South face with remains of Mill Pool wall

RAME HISTORY GROUP 2017

RAME HISTORY GROUP 2017

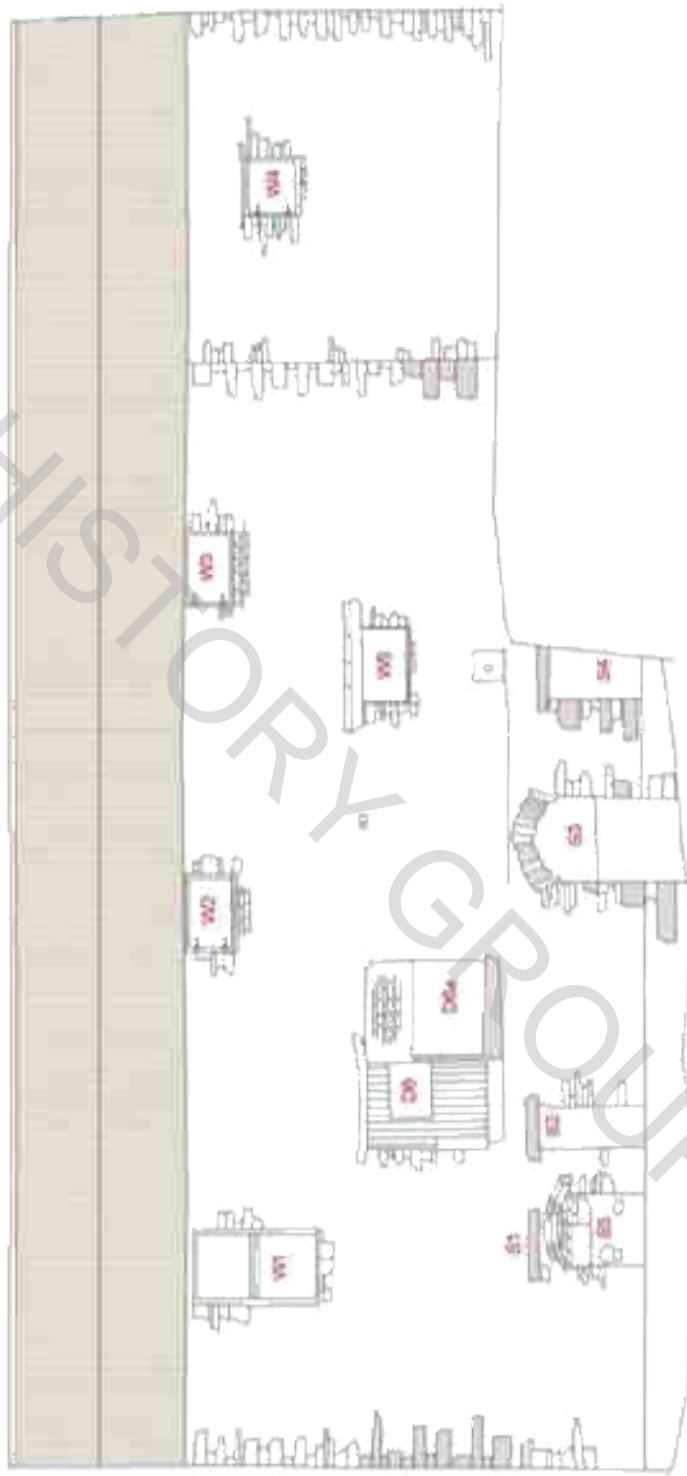

East Elevation

Architect: [unreadable]

EAST ELEVATION

RAME HISTORY GROUP 2017

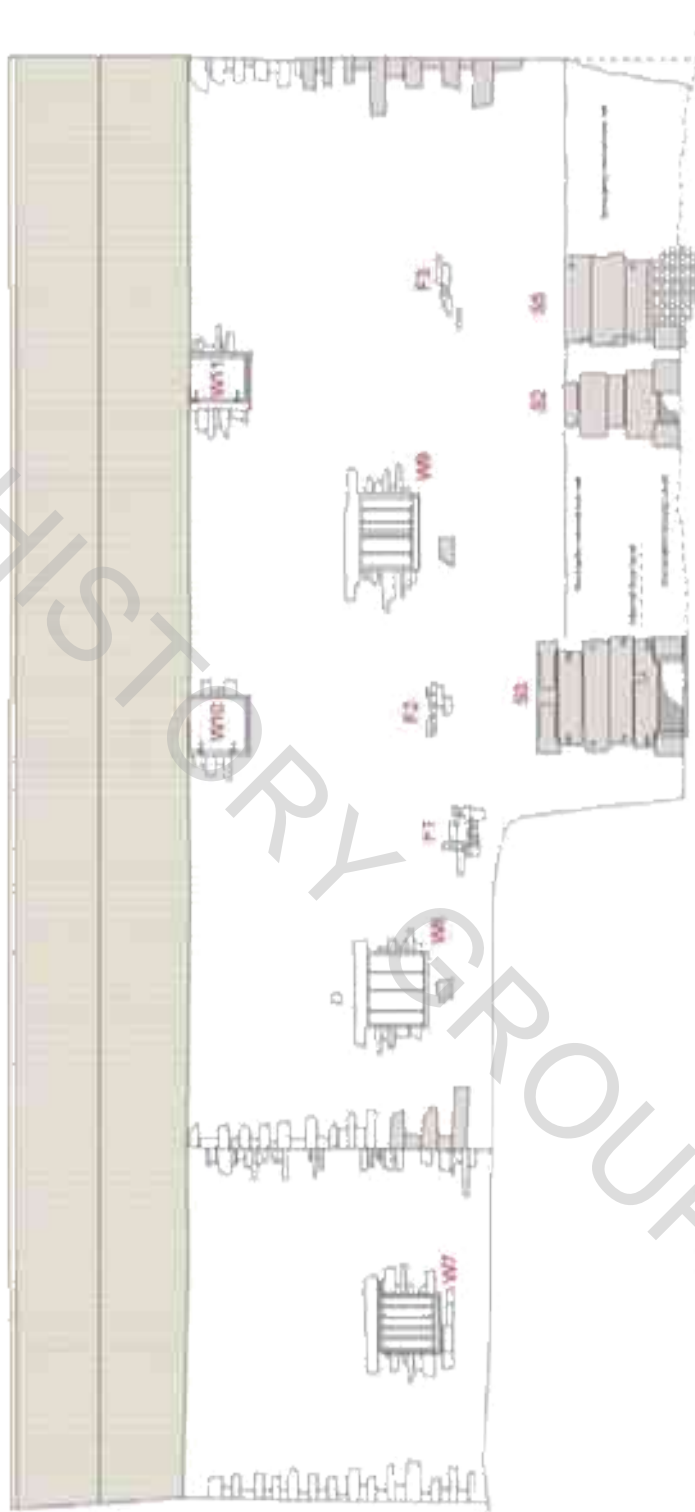

West Elevation

Scale: 1/100 - A4

WEST ELEVATION

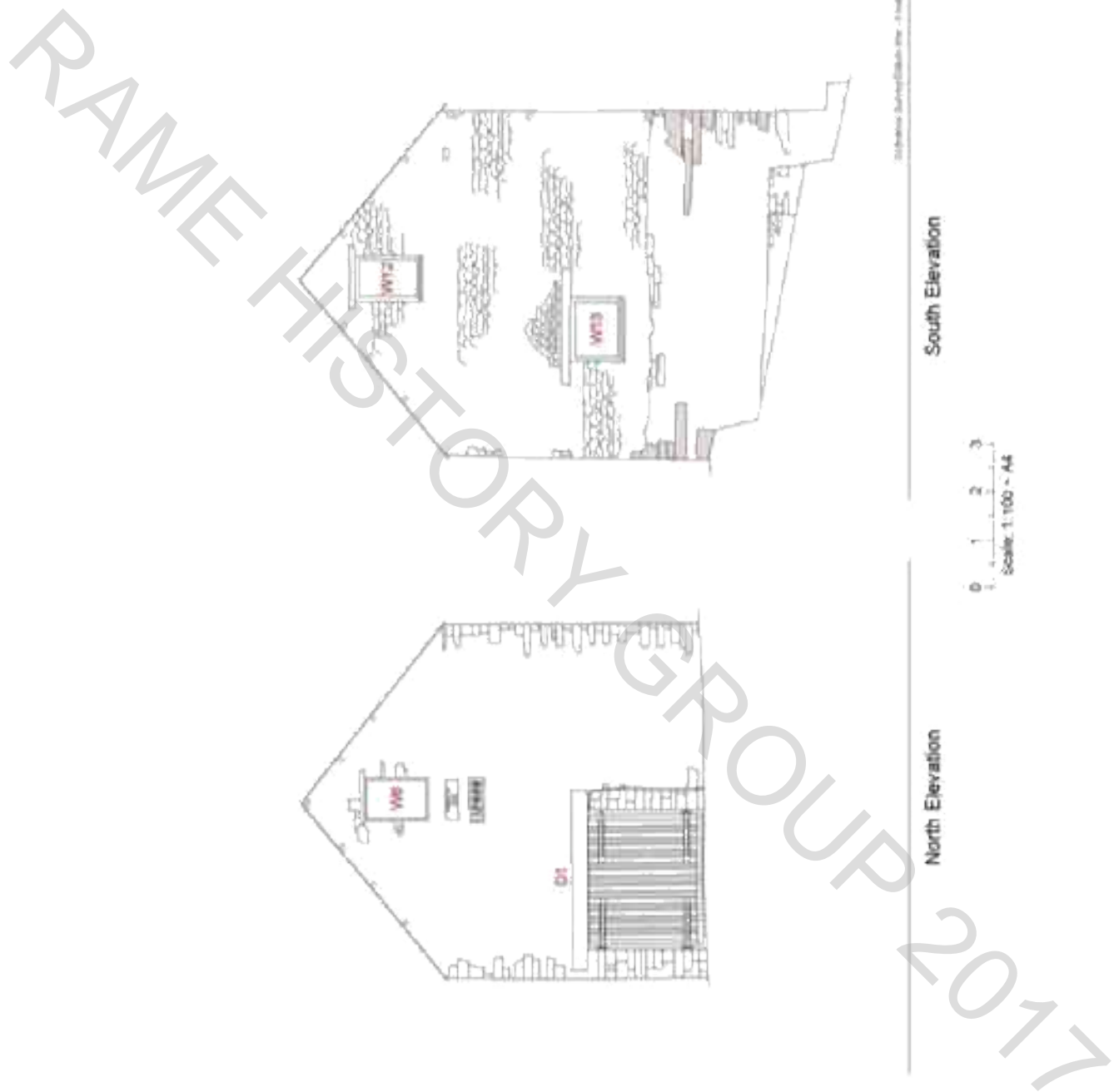

NORTH AND SOUTH ELEVATIONS

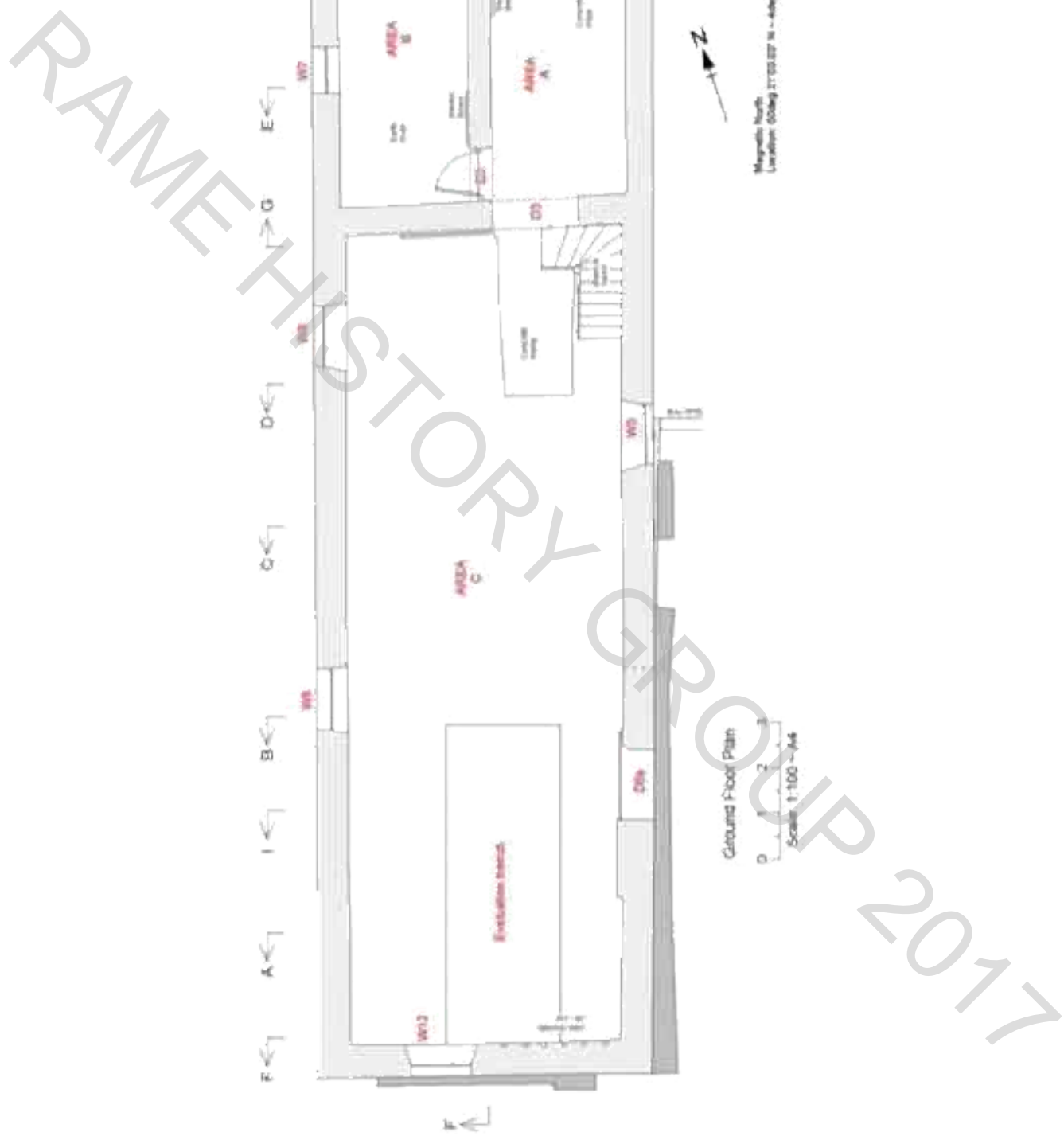

GROUND PLAN

5. EXCAVATIONS

5.1 Area A Ground floor; entrance

The floor was partly dug out by hand to allow machinery to pass through door D3 into the main mill building. The floor was concrete laid over tarmac, sand, silts and pebbles. (A.01, A.02, and A.03). This clearance disclosed a decorative threshold north of D3 made up of a semi-circular stone (S.01) set in pebbles. This proved to be a granite centre from a built up millstone with characteristic lines and dots on the edge. This is discussed below in Section 8.

An area of planking held together horizontally by smithy-made iron bolts lay to the east of the door and a baulk of worked timber laid width wise was set on a slight stone foundation wall. The eroded timber baulk (T.01) had some worked features in upper surface but was plain on the underside. It butted the side walls and appeared to have been placed there to help prevent local flooding of the entrance from the road. The single layer of planking (T.02) was not fixed to the baulk but had been cut to fit the space to make a rough floor. All the timber, identified by a professional shipwright as elm, was much decayed. The timbers were possibly part of an old barge or pontoon salvaged from the nearby shore rather than from the inside of the mill.

A plastic bag was found below the planking which rested on a bed of grey 20thC builder's sand (A.04). All timbers were drawn, photographed and then discarded

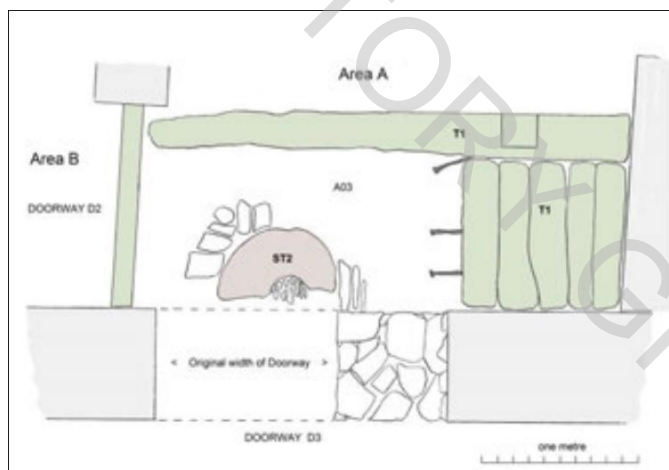

Plan of excavated features in the entrance areas



Excavation looking east

5.2 Area C: Ground Floor and Basement: evaluation trench and selective clearance of main mill

An evaluation trench was dug by hand and a light machine at the south end of area C. This showed that the worn and uneven concrete floor (C.01) lay over a loose laid brick floor (C.2) set on a layer of fine black clinker (C.03). Below this was a fill of red clinker (C0.4) with some waste bricks which was probed down to about two metres below the concrete floor. This clinker was later shown to fill the whole Basement down to the original stone floor level. The clinker came from the waste tips of the local brick works – there being two within half a mile of the mill. It was datable by the finds of early 20th century earthen wares such as teapots, marmalade jars, lemonade bottles and glass medicine bottles which had come in with the clinker waste.



Evaluation Trench looking south

The rest of the concrete and brick flooring was cleared by machine. Near the top of the clinker layer seven oak beams were embedded in the fill. These were set crosswise but spaced irregularly and were interpreted as floor joists (J1 – J6). They were roughly squared and in some instances badly eroded. A sample from J4 was dated by dendrochronology and provided a late 18th century date which sits well with the date of winter 1799-1800 from first floor beam B6 .

Two joist holes in the south wall (J7, containing timber fragment T2, and J8) were at the same level and could have held other joists set at right angles to the main series.

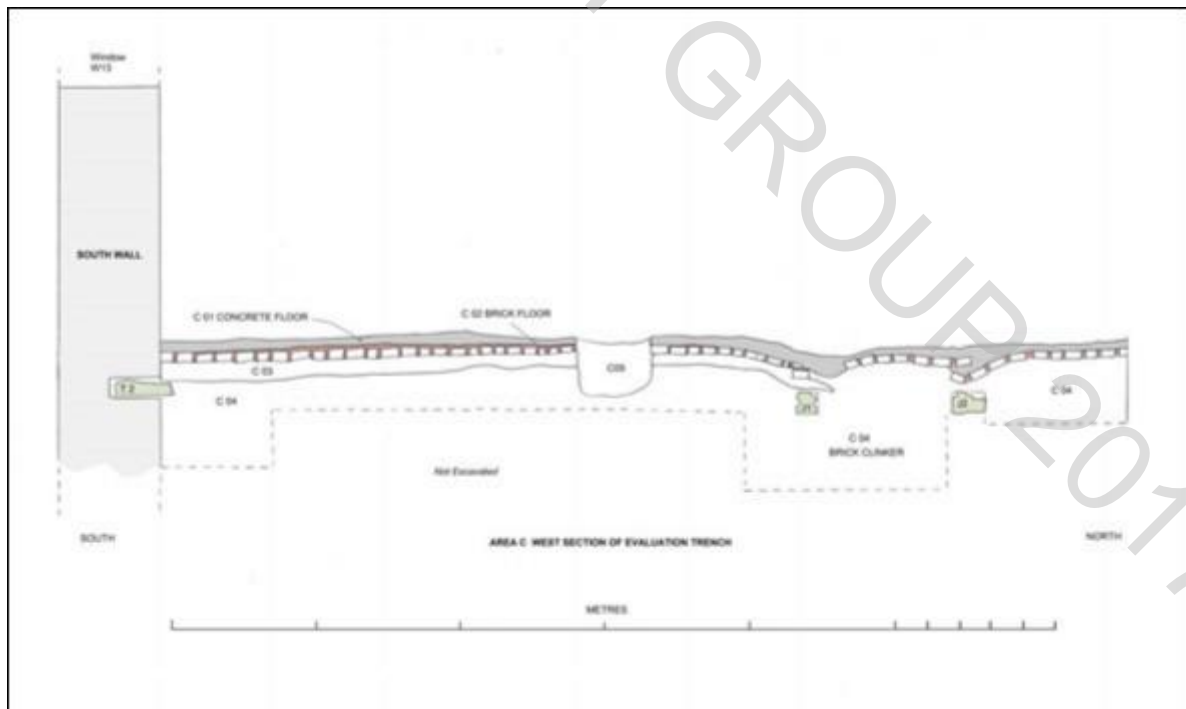

West Section of the Evaluation trench

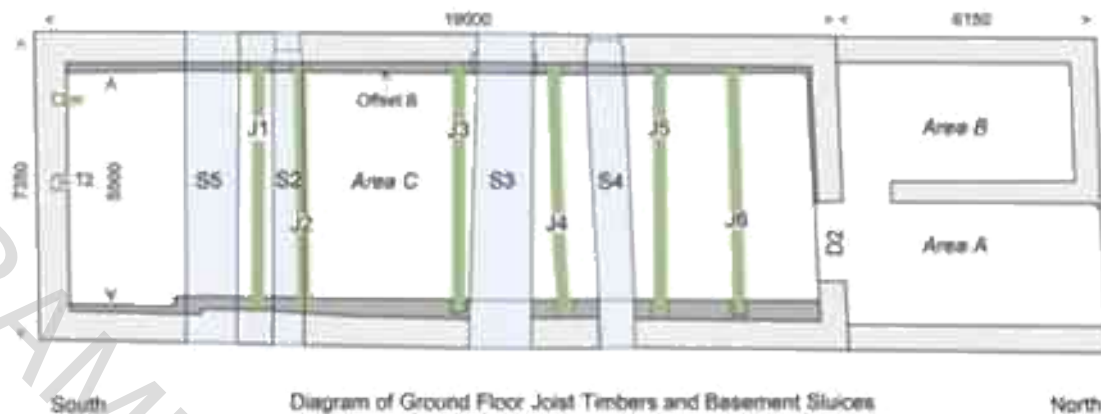

It was impossible to say whether these joists had been left in place during the infilling of the Basement or temporarily removed; some of the joist holes in the east and west walls which are just below the level of the ground floor offset (Offset B) were badly damaged. However they would have been useful to support planks while trucking in the clinker.

At the north end roughly between J5 and the north wall the brick flooring had been disturbed by a pit filled with darker clinker, stone and earth. This contained a noticeable amount of iron debris such as spikes from barges and pontoons, door hinges and notably the metal chassis and a wire wheel of two early 20th century charabanc cars. Joist J6 had been pulled out of position and lay on top of this ill defined pit and its socket in the west wall made smaller to take a later timber.

Clinker is a free draining material ideal for a fill that deals with tidal flooding. For this reason and to maintain structural stability the present owner decided to retain as much of it as possible within the building. Limited machine digging was therefore done inside the mill next to each sluice opening.

Areas adjacent to S2 and S5 west were taken down to low tide level and photographed but the wall above was unstable and had to be supported by concrete block work before full measurements were taken. Better access was gained to S2 and S5 east; the paved Basement floor was reached and the water channel accessed. The most useful clearance was a complete section across the building width of sluice S4 which gave access to the Basement floor, water channel and a full exploration of both sluice arch openings and alterations in the west wall.

S3 had been carefully blocked with concrete and steel struts through its length and was only partly accessible. All the sluice arches in both walls had been blocked in various ways presumably before the clearance and infill of the Basement with clinker. Details of these features are described in Section 7.5 below as part of the building record.

5.3 Excavation on the line of the Mill Pool wall

In preparation for the building of a new quay clearance of landfill and mud from the lake edge was done by machine. The area was very unstable and access was limited. Sightings of the main sluice opening beside the mill showed that it had most recently been repaired with brick to carry a drain pipe across the opening. It was not possible to identify any earlier structures. A number of dressed granite slabs were retrieved from this area and saved for reuse. Amongst these were some worked stones which are described below in Section 5.5.5.



Clearance of the foreshore to the south west of the mill and foundations of the new quay wall. Behind the opening in the block-work the remnants of an earlier adaptation of the Mill Pool sluice which had a twentieth century drainage pipe across the top can just be seen. Beneath and beyond the machine is the rubbish dump fill.

5.4 Excavation outside the west wall

A trench along the faces of the south and west wall for stabilisation and the insertion of a concrete sump and plastic drainage pipes gave brief access to the blocked sluice openings S2, S3 and S5. Limited measurements taken of S3 and S2 helped establish the relationship between the inside floor in the Basement and the lowest water levels in the sluice channels. S4 was not cleared due to the proximity of the electricity transformer pole.

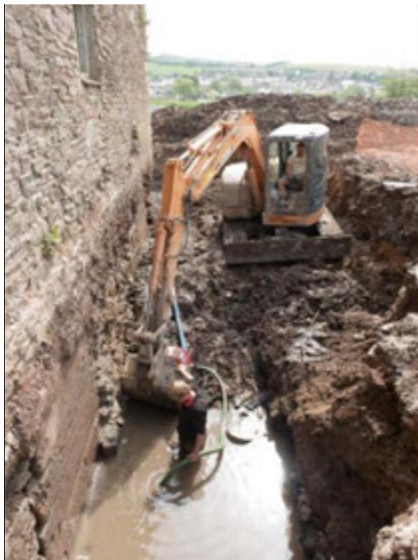

West wall drainage trench



West wall face, blocked sluices, left to right- S3, S2, S5.

5.5 The Finds

Finds came from several areas on the site:- inside the mill from Area A and Area C; from the mill walls as part of rebuilding or blocking of the sluices; from the lakeside silts and beach areas around the south end of the building and from the quay areas and the yard of the Mill House.

Most of the finds of iron, glass and pottery were recovered from the brick kiln clinker waste (C04) which was used to fill the Basement of the mill. The clinker had evidently been used as a local rubbish dump on the brickworks site before being brought to the mill. Many items were broken and burnt or warped by heat. Worked and dressed stones were collected from the local quay, the silts during excavation for the new quay wall and from the landfill on the south side of the building. Most of the millstones have been collected by the owner of the Mill House and are stored in his yard; they are recorded with his kind permission.

5.5.1 Iron

While there was no iron from the evaluation trench in Area C a concentration of iron finds came from the northern half of the Basement fill. This was predominately blacksmith-made iron spikes and bolts which could have come from boats, pontoons and wooden partitions. A careful search was made through the iron for any parts of mill machinery; this was disappointing and the only obvious items were a sack truck, a roller and parts of a sluice lifting control. Door hinges and a lock and some attached wood fragments may have come from a mill door but were undateable.

The most unexpected finds were the steel sub-frames of two vintage charabanc vehicles which had been buried near the top of the Basement fill at the north end. These were placed beside each other and lay north south. These were locally identified together with one a solid tyre and a wire spoked wheel as remnants of Edwardian vehicles owned and used by Skinners of Millbrook, the local garage and bus owners.



J Ellworthy



Skinners Charabanc Tours, Millbrook Quay 1914.

After excavation most of the iron was sold as scrap with the few items relating to the mill being retained by the owner, Mr Darren Newton.

IRON



Anchor from landfill



Pontoon showing iron bolts and spikes



Wheel hub from Basement fill



Mast straps, door fittings Basement fill



Iron work from Basement fill



Bolts and spikes



Bolts and spikes

RAME HISTORY GROUP 2017



Mill fittings and horseshoe



Charabanc chassis 1



Sack Truck and sluice control



Charabanc chassis 2



*Charabanc chassis from
Basement*



Charabanc wheel and tyre

2017

5.5.2 Pottery and Glass

The pottery included marmalade jars, lemonade bottles, ink pots, teapots, decorated plates and plant pots and discarded ornaments. There was a complete absence of clay pipes which together with the general style of the pottery strongly suggests a date in the 1930s for the main infill.

Information about the Cooper's and Hartley's marmalade jars and Biscombe lemonade bottles can be found on collectors sites on the internet. A selection of pottery was retrieved, sorted and photographed and the better items retained by the owner. The rest were bagged and reburied with modern coins in the Basement. A variety of twentieth century glass bottles and containers were mixed with the pottery but generally had survived less well. A small group of intact sauce, ink and medicine bottles are illustrated.

PRIME HISTORY GROUP 2017

POTTERY



Unglazed Earthen Wares



Glazed White Wares



Glazed Earthen Wares



Stone Wares



Blue and White Wares



Stone Ware Lemonade Bottles



Glazed and Decorated White Wares



Stone Ware Marmalade Jars

RAME HISTORY GROUP 2017

Ornaments



Burnt figurine, ?18th century

Torquay Motto Ware



20th century glass



Girl and dog

RAME HISTORY GROUP 2017

5.5.3 Bricks

A mixture of bricks came from the floor inside the mill, from the walls during alteration and from the nearby quays. These have not been studied in depth for this report as there were three major brickworks on the north shore of Millbrook Lake in the nineteenth century, all operating from about 1880. Two were within half a mile of the mill; Devonshire Brick Company to the west and Foss Brickworks (later South West Brick Company) to the east. Both were taken over by Westbrick Products Ltd, c.1914 and ceased work by 1935. The third company, at Southdown, was brought into the Westbrick fold in 1948 and worked until 1956. The clinker waste used to fill the Basement most likely came from the Devonshire Brickworks site as a small tramway is shown linking it to the mill quay on the 1912 O.S. map. South West Bricks stamped S.W.B are found widely throughout the Rame peninsula and have been endlessly re-cycled in the area. (Gaskell Brown, 1980)

BRICKS



RY GROUP 2017

*Brick clinker and kiln
wasters*



South West Brickworks

Bricks with plain frogs



Plain brick with no frog

RAMM
RY GROUP 2017

RAME HISTORY GROUP 2017

5.5.4 Stone: 16th century shaped granite

Four dressed granite items were found used as lintels and blocking stones in sluices S3 and S4 in the west wall. A piece of octagonal mullion (St 9) was included in the blocking of sluice S3. Also in this blocking was a slab (St 10) which was chamfered and stopped and may have been part of a door frame or fireplace. This seems to have been re-used as an edging slab as it has fixing holes on its outer, west face. Two different window sills each with a seating for a mullion were re-used as lintels on the inner and outer faces of sluice S4. These items indicate the high quality of the original Tudor building.

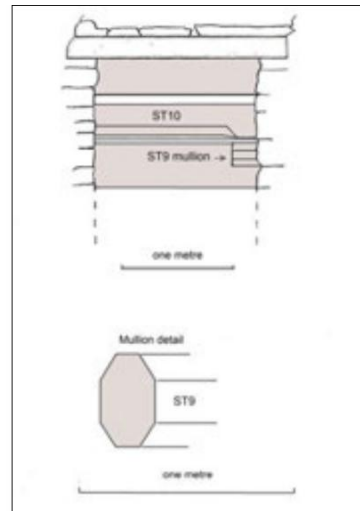

S3 west interior St 9 and St 10



S3 west exterior 16thC sill re-used as lintel

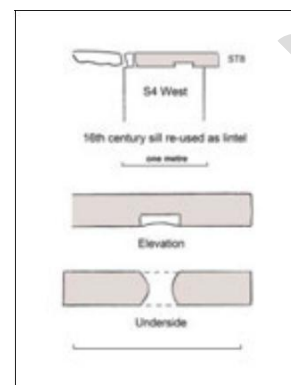

S4 west interior 16thC sill St 8 re-used as lintel

5.5.5 Stone: Dressed granite slabs

Clearance of silt along the line of the Mill Pool wall produced a quantity of dressed slabs which were probably edging or coping stones from the former wall or the 19th century tramway which ran from the nearby Devonshire Brickworks to the mill. Some of these had circular recesses at each end perhaps to take fittings for metal railings. A number had been used to block the sluice openings in the west wall. A simple key stone (St 6) was amongst these casual finds. Two shaped pieces used as quoins (St 7) in the south wall are of a much lighter coloured granite. Their date and original purpose has not been identified. All the loose pieces have been kept and if appropriate will be re-used in the renovation of the building and quays.

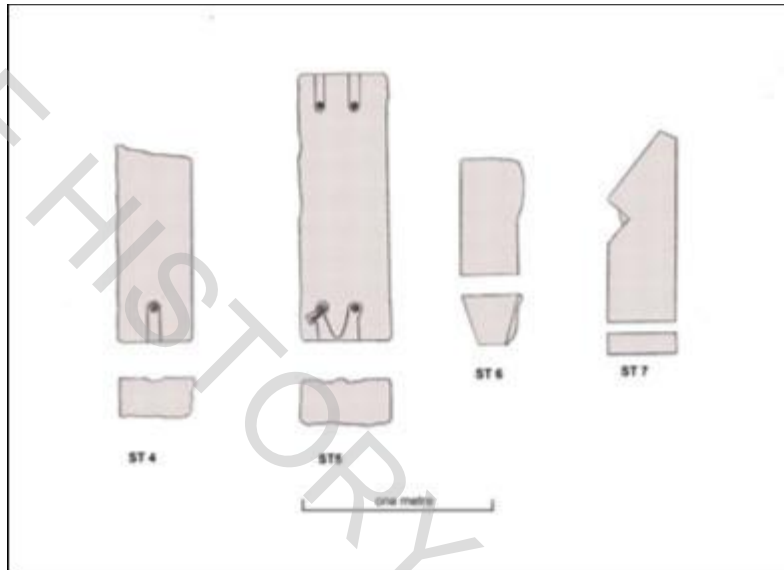

Stones St 4 and St 5 on quay; Key stone St 6; Quoin stone St 7

5.5.6 Stone: Millstones and Bearing block

Two millstone centres were found inside the mill. One had been used as a decorative threshold in the entrance area A; the other was part of the blocking of the east opening of sluice S2.

A complex bearing block clearly made to support iron axle of mill machinery was retrieved from the beach. These items and the millstones collected from the quay which belong to the owner of the Mill House are described in detail in the Millstone Report in section 8 below.



Granite slabs from silts now on the quay



Granite slabs including a key stone

RAME HISTORY

Key stone St 6



Detail of 16th century chamfered slab St 10 and mullion St 9 in the blocking of S3

Detail of seating in slab St 4



Detail Of 16th century mullion St 9 in S3



Detail of seatings for metal fixings in St 5



Stones re-used as quoins, St 7 to left, in south wall



*Re-used stones in outer blocking of S3 west
sluice with 16th century sill as lintel*

Bearing block as found in use as a mooring

RAIME HISTORY GROUP 2017

6. MILLSTONES CATALOGUE

by Martin Watts

Six millstones, whole and fragmentary, survive behind the Mill House to the north of Insworke Mill. These appear to comprise the remains of a pair of granite stones and a pair of conglomerate stones, together with a smaller complete granite stone and a granite millstone centre. A further fragment of a granite millstone centre was set in the ground floor between the northern Extension and the mill. These stones are described as follows:

1. *Complete runner stone*, granite, 1.16m diameter, 19.5cm thick at eye and 12cm thick at edge; circular eye 23.5cm in diameter. Slightly domed back (against wall); flat grinding face. Face dressed with 11 harps of 5 furrows, for clockwise rotation. Chases for straight bridge-type rynd, approx 42cm overall length by 8.5cm wide by 3.5cm deep

Comment: bridge form and dressing considered to be typical of 19th century

2. *Complete bedstone*, conglomerate, 1.17m diameter, 22cm thick at eye and 8cm thick at edge; circular eye 22cm diameter. Domed back (against wall) roughly finished; flat grinding face. Face dressed with 10 harps of 4 furrows, for clockwise working

Comment: single radial crack through stone from eye to periphery. Dressing typical of 19th century

3. *Approximately half of a bedstone*, granite, with large quartz crystals, 1.16m diameter, 13cm thick at eye and 7cm thick at edge; circular eye about 22cm diameter. Smooth finished domed back, facing outwards. Evidence of furrow dressing on flat milling face, but obscured by present position against wall

Comment: this may have formed a pair with number 1, but it has not been possible to compare the dressing on both stones

4. *Millstone centre*, from bedstone, granite. Octagonal, 50cm across flats, 16cm thick at edge. Circular eye 21.5cm diameter. Traces of furrows, dressed for clockwise working. Slightly domed back with smooth curve into eye. Edge faces of octagon are 'dressed' with lines, crosses and dots, to provide keying for outer blocks that would have made up the milling face. Each face appears to have a different pattern

5. *Fragment*, roughly one third, of conglomerate, probably a runner stone. Approximately 1.16m diameter, 19cm thick at eye and 11cm thick at edge. Domed back; flat grinding face. Crisp harp and furrow dressing, 4 furrows per harp, with stitching to lands at skirt, for clockwise rotation. Broken across eye, leaving only slight arc of circular eye and deep angular recess in grinding face, perhaps the remains of a bridge rynd chase

Comment: dressing typical of late 19th century. May have formed a pair with number

6. *Complete runner stone*, granite, 1.07m diameter, 9.5cm thick at eye and 11cm thick at edge. Domed back, with soft curve from full thickness of back (in excess of 15cm) to parallel sides of eye. Eye 21.5cm diameter. Flat grinding face, with 9 harps of 6 closely spaced furrows, dressed for clockwise rotation. Two generations of straight four-armed rynd chases: one 44cm span, 3.5-4cm wide by 3cm deep, the second 41-2cm span, 3-3.5cm wide by 2.5cm deep, with the bottoms of the chases slightly tapered, becoming deeper at eye

Comment: 18th century, possibly earlier. Although the furrows are of late 18-19th century form, they are closely spaced with relatively narrow lands

7. *Half of a millstone centre*, granite, with large quartz crystals. Irregular polygonal shape, approximately 80cm across the flats (maximum), 14cm thick, 23cm diameter eye. Edge faces have lines and

dots cut into them, apparently randomly. This stone was found set in the ground in the doorway between the northern Extension and the mill and one face is eroded from this use. The other face is featureless

8. A further granite fragment, probably part of a millstone centre, was found built into the internal blocking at a low level at the east end of S2.

6.1 Millstones Discussion

Stylistically, the oldest millstone is number 6, which is the smallest in diameter and displays two generations of straight four-armed ('stiff') rynd chases in its grinding face. It is made from a relatively fine-grained granite and is crisply dressed.

The remainder of the large millstones, of granite and conglomerate, are typical in size and dressing of 19th century stones for milling grain, either for meal or flour. The two granite stones, which vary in character, are presumably from Cornish sources. Granite millstones were made from surface boulders ('moorstone') on the granite outcrops in Devon (Fox 1994, 153-7; Robinson 1981, 333-4) and the same method of working presumably took place in Cornwall.

The conglomerate millstones are likely to be what were termed 'Welsh' stones, made of Old Red Sandstone conglomerate from quarries on the Gloucestershire/ Monmouthshire border, which were worked for millstones in the later medieval and post-medieval periods (Tucker 1973, 11-12; Tucker 1977). Millstones from these quarries were widely distributed throughout the south-west peninsula, being transported by boat from the river Wye into Bristol Channel ports, from whence they were often moved over land (see, for example, Graham *et al* 2005, 66-7). It is also possible that they were brought round to the south coast of Cornwall and Devon by sea.

Although the granite stones (1 and 3) and the conglomerate stones (2 and 5) may have been paired for working, there are visible differences in stone texture and quality between the top and bottom stones. This suggests that they were not originally acquired as pairs, but rather have been put together at some time during their working lives, perhaps as an economic expedient. This also perhaps reinforces the statement that there were latterly four pairs of millstones which, from this evidence, would be two pairs of granite and two pairs of conglomerate.

Catalogue numbers 4 and 7 are particularly interesting, being granite centres from built-up millstones. It is most likely that the grinding faces of the millstones of which these formed part were made of French burr stone, of which a number of fragments can be identified at Insworke Mill, re-used as building stone in the walls of the mill. All of the burr fragments that have been visually identified are in the upper parts of the exterior walls of the main mill building, which are considered to have been rebuilt in about 1800. In England, French burr stones were almost always made up of shaped blocks cemented together and backed with plaster of Paris. A number of granite millstone centres have been found throughout Cornwall, and have been simply described as 'decorated millstones' (Tangye 1992, 66-9). Their function was to provide a more economical and solid millstone centre, around which blocks of French burr stone would have been built up and the whole bound with iron hoops around the circumference. The area around the eye or centre of a millstone does little work other than drawing in the grain (Russell 1944), so the more expensive and harder French burr was used for that part of the stone where the serious milling was carried out.

There is no good dating evidence concerning the use of these centres, although some examples have curved rynd chases, which suggests they may be of 17th century date. The blocks from which French millstones were built were usually imported as ballast and the earliest unambiguous references to their import date from the second half of the 16th century (Ward 1993, 8). The dots and lines cut into the edges of these centres are considered to have been to provide a key for the mortar that cemented the blocks from which the millstone was made together, rather than having any particular decorative significance.



Millstone 1: granite runner stone



Millstone 4: granite millstone centre



Millstone 2: conglomerate bedstone



Millstone 4: granite millstone centre



Millstone 3: half of granite bedstone



Millstone 4: detail of side face

RAME HISTORY GROUP 2017



Millstone 5: part of conglomerate stone



Millstone 7 (CGB)



Millstone 6: granite runner stone



Fragment of French burr stone in north gable wall of mill



Millstone 6: detail of eye and rynd chases



Fragment of French burr stone built into east wall of mill



Millstone 7 (CGB)

7. BUILDING RECORD

7.1 Phase 1: 16th century

The finely carved 1598 date stone on the north face of the building provides the evidence for the first phase of the mill. Re-used 16th century granite window sills, mullions and a chamfered door jamb survive as blocking stones and lintels



These indicate that this was originally a high status building. Structural details in the lowest parts of the east and west walls fit this dating. These walls established the footprint of the building which is some 19 by 7.5 metres. Irregularities in the plan of the mill evident inside the south wall were adjusted in the Phase 2 rebuild. The Mill Pool wall with two sluice gate openings would have been established at this time and also presumably the Mill House although the present Mill House north of the mill has no obvious 16th century features. The 1795 Agreement to repair and rebuild includes both the Mill and the Mill House (Appendix 12.2).

7.1.1 The Basement: Exterior East Wall

The most distinctive features are the four sluice openings visible in the east face of the mill below tide level. Three narrow ones have flat granite slabs as lintels and the fourth is a wide arch with stone voussoirs. All are integral with the wall and these are now blocked. The fifth opening with a brick headed arch is clearly a later alteration. Corresponding openings were partially cleared in the south (back) wall but are now covered by modern fill inside and out.



The East wall at low tide showing the sluice openings at Basement level.

From left to right; the flat granite lintel and blocked opening of S1 is cut away by the brick-headed and blocked arch of S5. Immediately to the right is the granite lintel and blocked opening of S2. The large arched opening of S3 with stone voussoirs is now part blocked across the inside width of the mill by reinforced concrete. At the extreme right is the lower level sluice arch of S4.

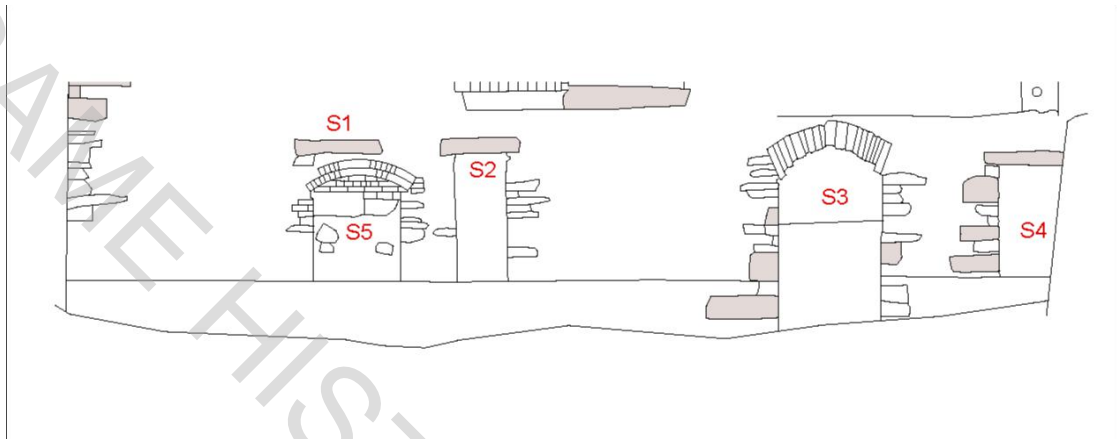

Detail of the sluice arches in the Basement of the exterior of east wall. Granite is shaded



Details of the sluice arches in the east wall: left S1, S5 and S2. Right S3 and S5

7.1.2 The Basement: Exterior West wall

The recording of this area was only possible for a few hours while drainage pipes were being inserted. The outside face of sluice opening S4 which was expected to have retained most information about the 16th century structure was not cleared owing to the proximity of the electricity transformer pole. The carefully shaped seating for sluice boards at the base of the sluices S3 and S2 may however be part of the original 16th century structure.



West wall at Basement level looking north and east showing the granite blocking stones in sluices S3, S2 and S5. This was the only point on site where the bottom of the sluice channel was accessible and measurements from this have been projected to establish the levels in other channels. The blocking is part of Phase 4 twentieth century work and is discussed below (Section 7.5). The rough wall face in between is the result of stone robbing during 1960s landfill work of the plinth which originally gave access to the sluice controls. ee historic photograph (Section 3.5) above. Note the effects of tidal erosion on the foundations of the south west corner of the building which caused instability. The wall above sluice opening S5 had to be supported by concrete block work when first cleared late in De-cember 2010.



Details of Sluice S3: seating for sluice boards possibly 16th century

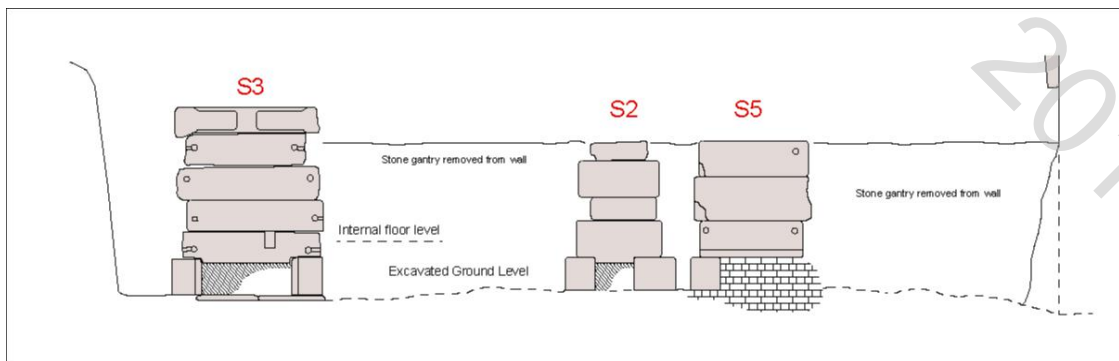

West Wall Exterior: Basement Sluice blockings

7.1.3 Basement Interior



Looking south across the sluce channel and openings of S4. The opening to the left (east) is intact and is faced with dressed granite blocks. This is part of the original phase 1 build and presumably 16th century. The lower part of opening to the right (west) is also faced with granite up to a change in level (Offset A). The opening and wall was rebuilt above that point and a 16th century sill stone was re-used as a lintel. The Basement floor was paved with large irregular slabs of local slate (C06) and though the channel edge is disturbed this represents the original flooring of the early mill.

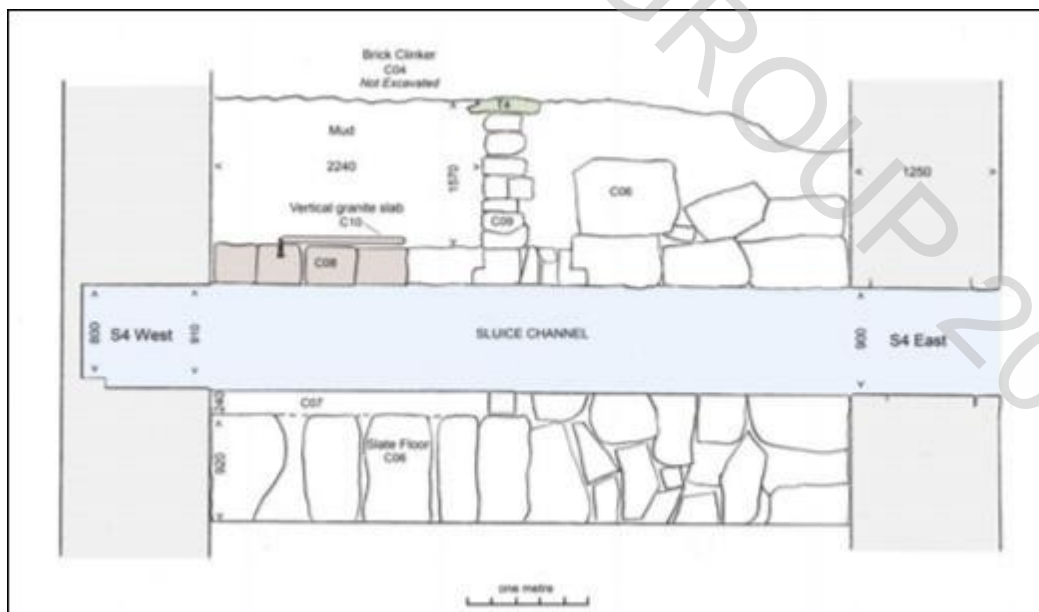

Plan of Basement Floor and sluce channel S4



S4 Sluice channel and paved floor looking south west. Note the lack of paving in the area below the ladder which was probed to at least half a metre. This was edged to the south by a vertical slab of granite (C10) and bounded by the footings for a wall (C09). This may have provided space for gearing. See Section 8 for discussion of this area. A fragment of timber (T4) perhaps part of original structure projected from the face of the clinker fill.



S4 Sluice channel and paved floor looking south east. Original granite quoins and lintel in the sluice opening. Joist holes from Phase 2 in wall above. Concrete blocking of sluice S3 beyond.

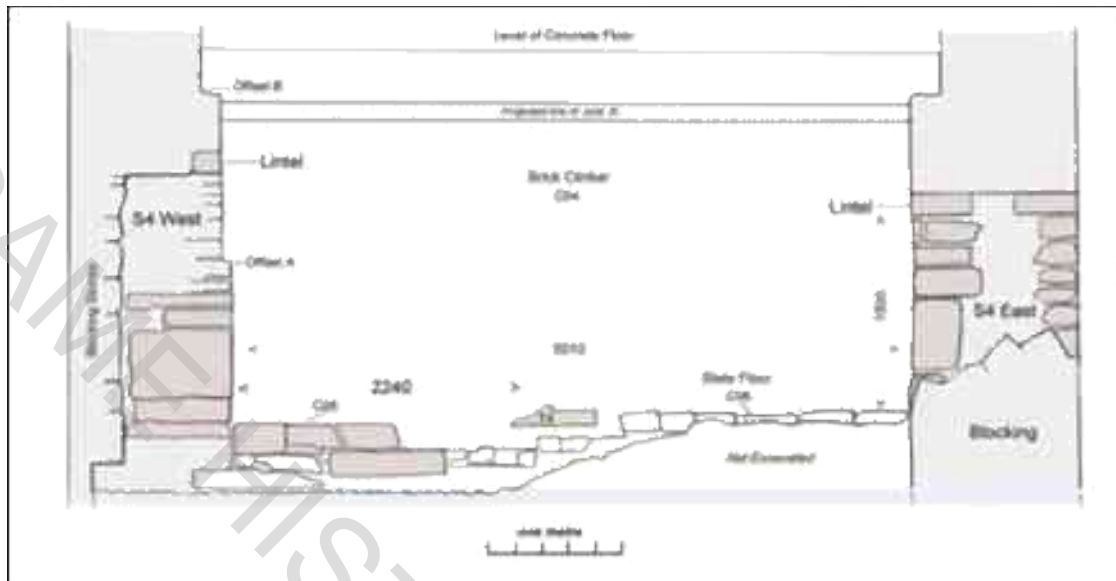

Basement: Section across sluice channel S4 looking north

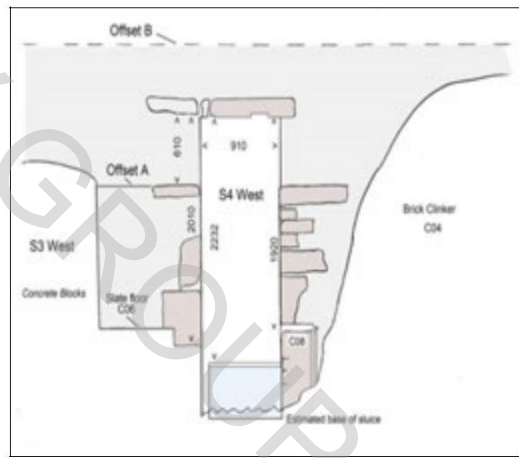

Basement: West wall with sluice S3 and concrete blocking to left. Sluice S4 with granite lined water channel and paved floor, granite quoins up to Offset A. Phase 2 rebuild above with re-used 16th century lintel, joist holes below Offset B and blocked sluice control features F1 and F2 above

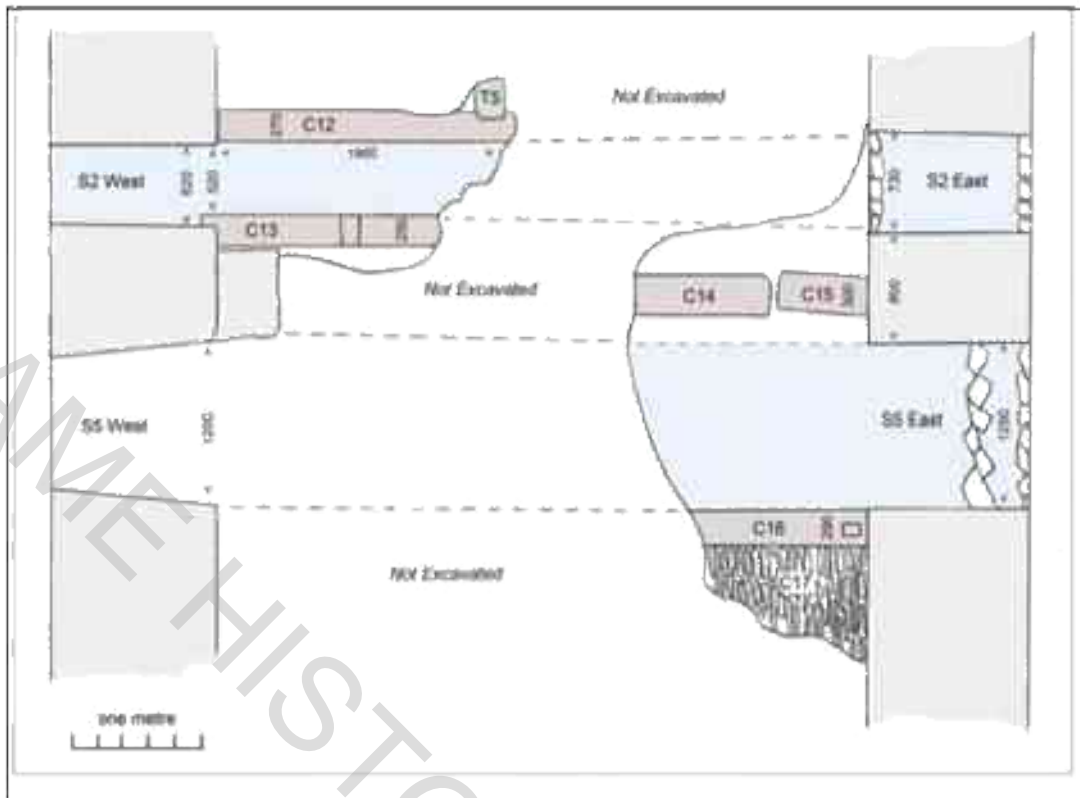

Basement Plan of Sluice channels S2 and S5



Sluice arch S5 and S2 West arch



Sluice channel S2: narrow granite slabs lining the channel



Sluice arch S2 with concrete blocking in S5 to left

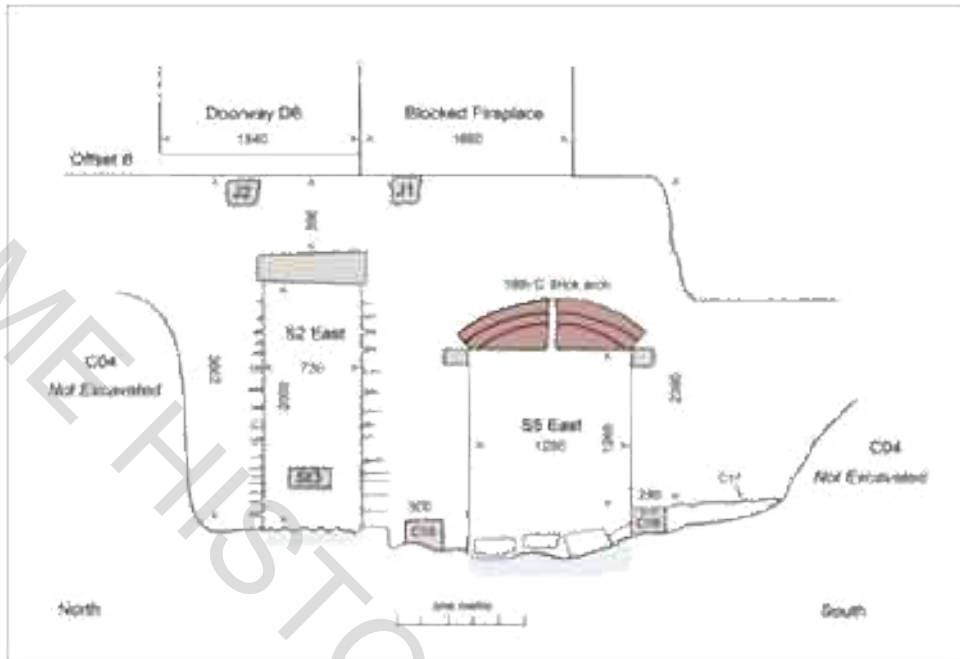

Basement Interior Area C east elevation of sluces s2 and s5



Basement Interior: east wall with blocked sluice S2, brick arch of sluice S5 and pitched paving on floor to right



Sluice S5 granite edging of water channel



Detail of 19th century brick arch S5 in east wall



Detail of pitched flooring south of S5

7.2 Phase 2: Late 18th century/ early 19th century

Between 1598 and 1795 the only documentary material so far recovered is the 1772 advertisement offering the mill and mill house to let. The Agreement of 1795 between the miller William Bickford and Lord Clinton to rebuild the mill, makes clear that it was by then dilapidated. Despite the agreement actual work did not begin until 1800. This date is supported by tree ring analyses, particularly of a sample from a first floor beam which gave a felling date of the winter of 1799/1800.

Economic factors such as the impact of the Napoleonic Wars in an area close to the Naval Dockyard, which was established in 1691 just across the River Tamar and the military importance of the town of Plymouth, may well have made it worthwhile to rebuild Insworke at the end of the 18th century.

The survey of Lord Clinton's estate in 1809 valued the mill at £3,522, a not inconsiderable sum as compared with the Ropewalk and Limekiln at Voss valued at £426 and the whole of Insworke Manor Farm at £16,212. The tenant of the mill at that time was William Bickford.

Structural evidence shows that using the foundations and sluice openings of the 16th century Basement the mill was rebuilt from the ground level up, with first and second floors and a loft under a slate roof. Access from the road was through the north wall at ground floor level with another door into the loft, perhaps originally with a locum over it, to take grain sacks from a hoist. On the

south front another door allowed loading and unloading of barges. Along the back wall adjoining the Mill Pool wooden staging or a stone platform gave access to the sluice controls. The lower parts of the wall used granite quoins stones but slate-stone higher up. A notable feature was the occasional inclusion of French Burr stone fragments from worn-out millstones. Although *mola francisca* were imported in medieval times unambiguous references to French burr stone only occur from the late 16th century onwards and help confirm the evidence for the rebuilding of the mill.

Three water wheels may have continued in use in the basement which had oak joists at ground floor level to take a planked floor. The first floor was supported on substantial chamfered beams, one of oak, the rest of elm. The elm tie beams to the roof trusses also supported a loft floor.

In watermills the loft space commonly held storage bins for grain which was then fed down through cleaning machinery to the millstones on the first floor; then down again to the ground floor for bagging and dispatch.

At Insworke Mill there is some evidence that a less common arrangement existed. Three iron hasps set in the faces of first floor beam B5 may have been used to lift up millstones for dressing. If so the millstones could have been set on a hurst frame or a low mezzanine floor based on the ground floor. Examples of this are known from nearby Antony Tide Mill (now gone) and at Beaulieu Tide Mill, Hampshire, which has been restored. This is discussed fully in Section 8.4 below. At Insworke the first floor would have been used as a grain store as well as for cleaning machines. This idea is supported by the evidence of a sack ramp on both sides of the door (D4) inserted in the north wall to connect with the Extension building.

As the mill had been very thoroughly stripped of flooring, partitions and pulleys it was not possible to be sure of other arrangements which would have altered over time. Access between floors would have been by simple wooden stairs and ladders but stones (F5) in the south face of the north wall at first floor level suggest that formerly there was a more substantial stair from first floor to the loft. The most recent wooden stair was in the north east corner until 2011. The late 18th century mill was lit by ten windows, originally with wooden lintels, at ground and first floor levels. These remained in use with only slight modifications until the present day.

7.2.1 Ground Floor

Clearance of the 20th century concrete and brick flooring and partial removal of the clinker infill revealed the eroded remains of six floor joists which originally formed the ceiling to the Basement of the mill. These were of oak and had only been roughly squared. There were no seatings for plank flooring; the floor presumably being loose laid on top. These joists were seated in irregularly spaced joist holes in the east and west walls but seemed to have been taken in and out of the walls as the holes were damaged. The west wall showed clear evidence of rebuilding as it was realigned above Offset B. The upper parts of the sluice openings in the west wall had also been modified somewhat crudely using a 16th century window sill as a partial lintel for S4 and a slab of granite for S3.

The first floor was originally constructed of 8 substantial beams which retained housings for planking above. Beam 8 had been removed in the 20th century. Beam 6 was oak and had a felling date of the winter of 1799-1800. All the others were elm some being good quality but others very irregular. As all had rotten ends where they sat in the walls supported on levelling timbers they were cut down and measured within the mill.

Doors in the north and east walls had been modernised in the 20th century but window openings had retained simple, though rotting, timber lintels on the inner faces.



Section through Insworke Mill looking west



Looking south west: ground floor joists, J3 (with scale) and J4 on each side of sluice S3 lintel. Blocked sluice control F2 in the wall above



Looking northwest: S3 (left) and S4. Joists J3 and J4 removed, J5 beyond. Blocked sluice controls F2 & F3 in the wall above



Looking north: ground floor joists removed. Showing the surface of the clinker fill in the Basement at the south end



View along the west wall a looking south. Showing Offset B above Offset A which is assumed to be the top of the 16th century build. The Phase 2 mill was slightly re-aligned above Offset B.

**7.2.2 First Floor
Beams**



ROYAL HISTORICAL SOCIETY GROUP 2017

Ground floor looking north



Ground Floor looking south with Beam 5 showing an iron hasp on the underside in the foreground



Ground floor looking north with Beam 4 in foreground. Remnants of a wooden hopper from the upper floor showing as sawn off vertical timbers

First floor beams from above looking south. Beam 2 in foreground. Beams were numbered north to south



First floor beams cut down looking south with rot-ten stumps retrieved from the wall in the foreground



First floor beams cut down with Beam 5 in foreground. Note the iron hasps in the side and underneath which would have been used to lift the mill stones for dressing.

RAME HISTORY GROUP 2017



Beams 1 and 2

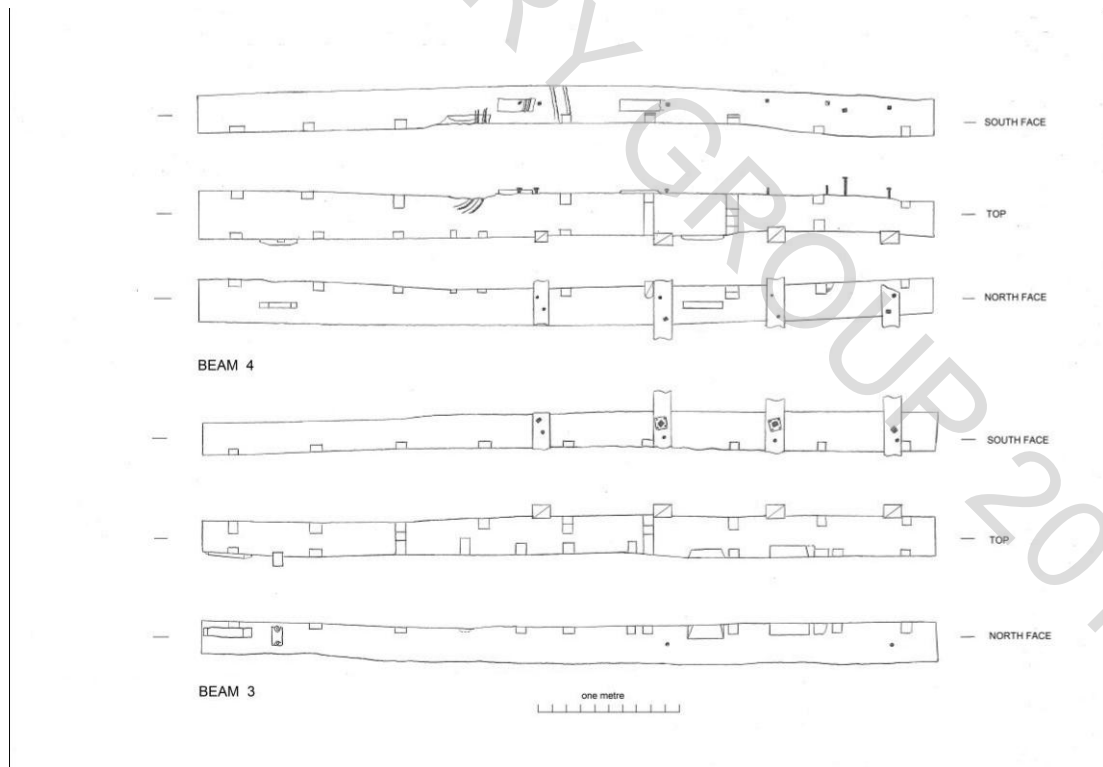

Beams 3 and 4

RAME HISTORY GROUP 2017

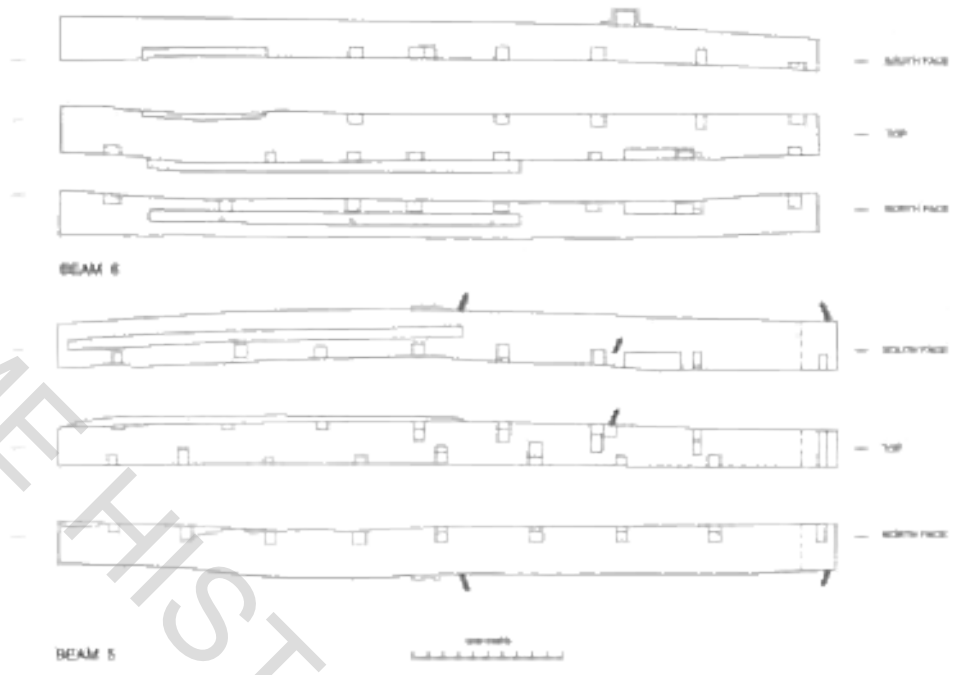

Beams 5 and 6

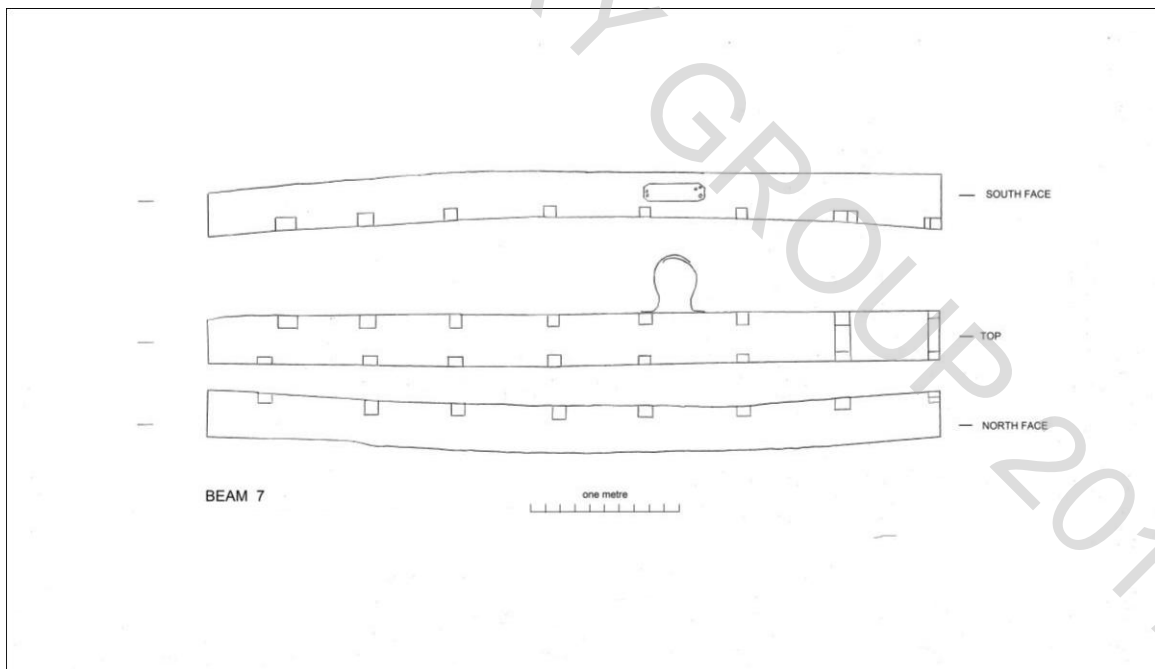

Beam 7

7.2.3 The First Floor and connections to the Extension

Remnants of the first floor layout, with rotting ply wood flooring laid on the original floor beams, were still in place in 2010. A sloping sack ramp survived on both sides of door D4 which had been cut through in the 19th century from the Extension into the first floor. The original modified 1800 door D5 retained its sack ramp inside the main building.

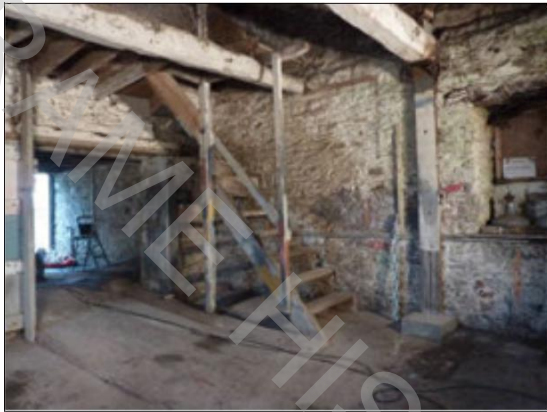

Ground floor looking north east to stair. Beams 1 and 2 above.



First floor looking north west. Sack ramp from door D4 to the Extension with sack ramp to door D5 above



Ground floor looking north to stair. Door D3 with 20th century sliding door and D1 beyond



Looking north on the first floor; stairs to right, door D5 and sack ramp above



Looking from ground floor up north east through 2

first floor to door D5 and roof. First floor Beams 1 and 2 with roof tie beam D above

7.2.4 The Roof timbers

The roof structure was of two main phases. The first phase with halved and crossed principal rafters pegged with treenails had two rows of pit sawn purlins and some upper collars. The Trusses were marked with Roman numerals I - VIII from north to south in the main mill. This phase was assigned to the 1800 rebuild. The second phase had machine cut purlins and double ridge timbers which were fixed with blacksmith made iron ties. These were used in the Extension and had been added to the old roof in the main building in the 19th century. Some additional minor repairs were contemporary with the twentieth century corrugated iron roof.

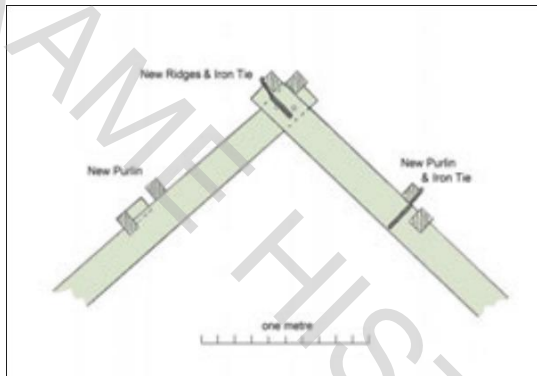

Area C Roof Truss I

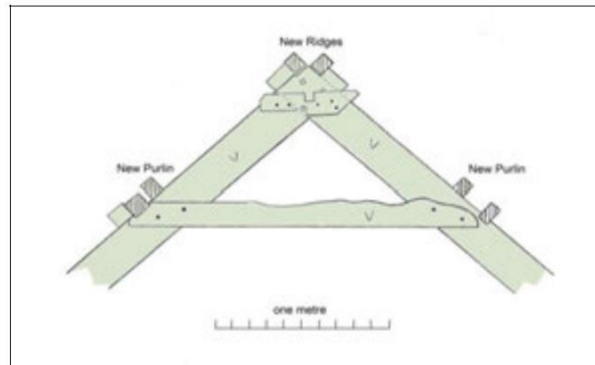

Area C Truss H

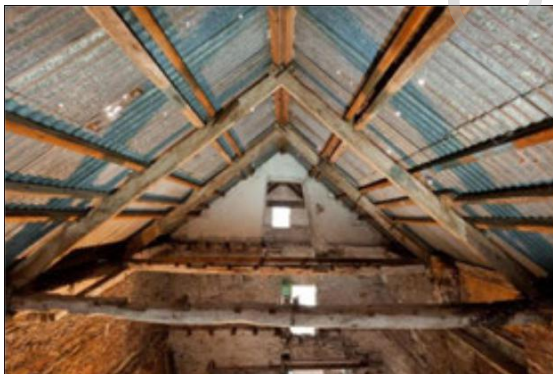

Roof structure looking north



Looking south: apex truss V



Looking north: apex

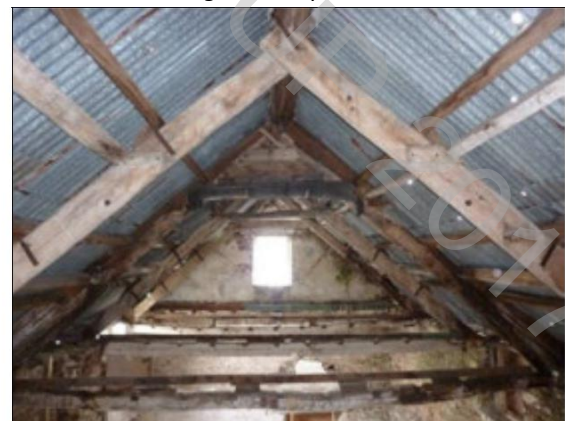

Looking south

7.3 Phase 3: 19th century

7.3.1 Sluice Channel S5.

Two major changes were probably made in the mid - late 19th century. Towards the south end of the mill a new wider sluice channel was constructed. This has an arch of nineteenth century bricks. Its pair on the opposite side of the building had a timber lintel. This new opening cut away the early sluice, S1, which was blocked up on the east face. The width of the new sluice is almost the same as the stone arched sluice S3. The historic photo taken in 1937 looking east from the Mill Pool shows a stone platform on the back of the mill with only two openings in line with these wide sluices. It seems that this was a major remodelling probably to allow the installation of two larger waterwheels perhaps of iron. The large bearing stone, St 1 (discussed in Section 8.4.3) found discarded on the beach, would fit with this suggestion. Inside the building the stone floor associated with the newer sluice, S5, was at about the same level as the stone floor at the north end but was of pitched stone (C17). The water channel was demarcated by lengths of dressed granite (C15 and C16) and these also had been used for the adjoining channel of S2 which may have been re - made at this time.

7.3.2 Extension building.

An Extension to the north end of the original mill provided covered access for carts and extended storage on the ground and upper floors. Straight joints clearly separate this new build as does the geology of the walls where quoins are predominantly slate-stones and there is a noticeable inclusion of blue elvan stone. A trap door in the first floor of the Extension and a sack ramp through a new first floor door (D4) gave access to the old building. The building is divided into two, areas A and B, by a wall on the ground floor and had a first floor and a loft. The roof timbers matched repairs to the main roof which were fixed with iron ties. This part of the building pre-dates 1911 as it appears on a photograph of that date; but the recently reviewed date stone of 1861 gives a very likely date for this Extension.



The mill from the north east showing the 19th century Extension with cart door onto the road and date stones for 1861 and 1598 in the wall above

The original doorway through the north wall of the old mill was altered and widened in the 19th and 20th centuries with a wooden lintel over the interior door D3 later reinforced by a steel joist to take sliding door on the south face.

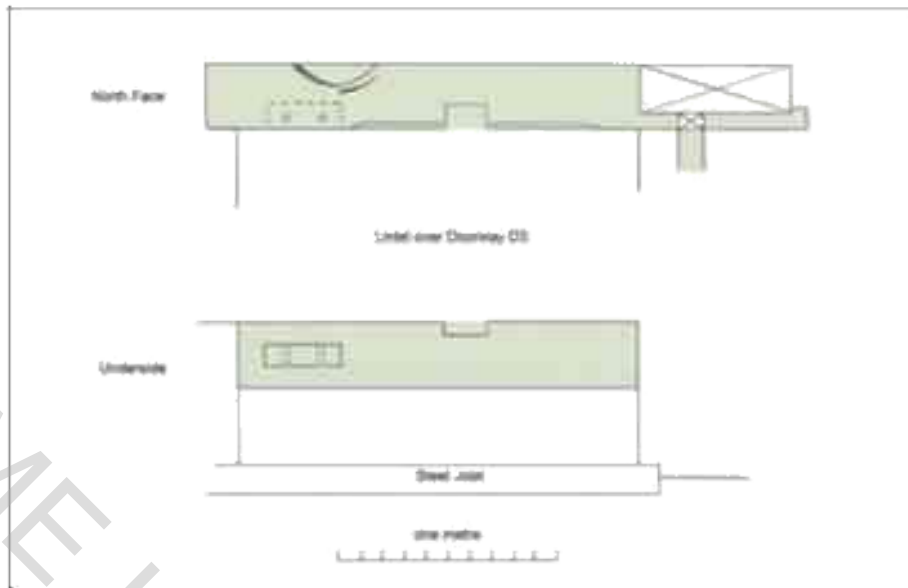

The lintel over door D3 looking south from the Extension into the main building. This is a re-used timber, originally part of the framework inside the main mill. The front corner was chamfered and the mortice to take a cross timber has holes for wooden pegs. Note the wear marks from a pulley to the left.



Looking south through the Extension Area A. Door D2 to the right; door D3 ahead. Excavated area on threshold of D3



Looking up to wooden lintel and steel joist of door D3



Looking north from door D3 through Area A out to the road



Wooden door D2 inside Area B of the Extension



Area B detail of 18th century lock inside the door



Area A Looking south up to doors D5 (above) and D4 (below). D5 was the original opening in the north wall of the main mill for hoisting sacks into the loft; D4 was broken through when the Extension was added



RUNTIME HISTORY GROUP 2017

Detail of early hinge on the inside of ground floor door D2



Electricity board in Area B next to the ground floor doorway D2

Detail of doorways D5 and D4 with partial remains of the sack ramps



LABORATORY GROUP 2017

*Extension looking into roof showing iron ties
on trusses and the original north wall of main
mill building*

RAME HISTORY GROUP 2017

7.4 Phase 4a: 20th century

Trade directories and oral histories suggest that milling had ceased by 1914. The building was then used by members of the Parsons family to sell grain, fertiliser and coal as well as being the base for their Millbrook Steamboat Company (Kittridge, 1984). Oral history collected in 1963 recalls “two large waterwheels about fourteen feet across and one small one for auxiliary lifting”. Rex Wailes states the mill had “two wheels each driving two pairs of stones.” It is not clear whether these wheels were still in place in the 1930’s when Wailes’ photos show that the sluice channels on the front of the building are blocked up and the back of the building in generally derelict state.

Alterations at the south end included the addition of a fireplace and chimney inside the east wall just south of the re-positioned ground floor doorway, D6. The south gable wall may have been at least partially rebuilt at the upper level as bricks are visible in the apex. Patches of re-pointing and of local rebuilding with narrow slates-stone are noticeable at first floor level in the north west and south west corners. This may have been done at the time the slated roof was replaced by corrugated iron and the main roof trusses and ridges were supplemented by new timbers.

A row of small joist holes hacked into the inside of the south wall to support a subsidiary floor, the building of the fireplace and the enlargement of window W1 appear to be alterations for 20th century office space which caused the removal of the first floor beam, B8.

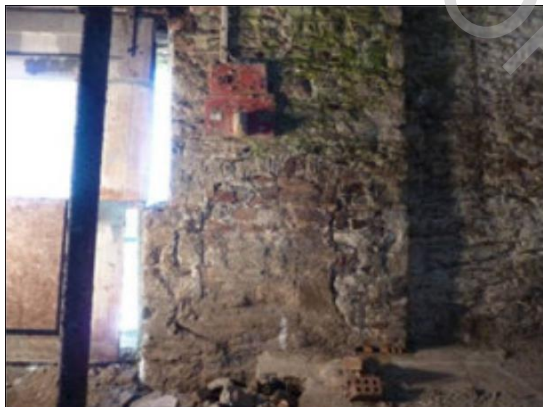

Early 20th century blocked Fireplace in the east wall

Joist holes in the lower part of the south wall for adaptation for office

RAME HISTORY GROUP 2017

RAME HISTORY GROUP 2017

7.5 Phase 4b: 20th century

Sometime in the 1930s a major change took place. All the sluice openings in the Basement were blocked off by granite slabs in the west wall and dry stone walling in the east. A narrow gap at the bottom of each sluice arch in the west wall was left for drainage. The Basement was cleared of machinery and deliberately infilled with brickworks clinker (C04). The Ground floor joists J1-J6 were left in place probably to help the filling process. The fill incorporated early 20th century pottery such as marmalade jars, lemonade bottles teapots and glass medicine bottles. There was a noticeable absence of clay pipes.

This rubbish probably came from the nearby Devonshire Brickworks Company site. These closed down around 1935 (Gaskell Brown, 1980) and the finds recovered from the Basement mostly date from the first quarter of the 20th century. However notes made by Rex Wailes suggest that water-wheels may still have been visible as late as 1937 (Section 8 below). The steel frames of two Edwardian vintage charabanc vehicles were placed in this fill near the north end.

The clinker is permeable and proved to be an excellent way of coping with the constant movement of tidal water through the building. It was floored over by loose laid bricks (C02). Sluice S3 was closed with concrete blocks across the full width of the mill leaving only a low level drainage channel.

The later use of the mill as a coal store and boat repair shed led to further modifications. These included laying of a concrete floor (C01), enlarging doorways D3 and D6 and replacing doors on steel rollers, the raising of the entrance area A to prevent flooding, a toilet cubicle and installation of electricity. The first floor beams became rotten in the wall sockets and substantial props were put in at each side standing on concrete pads.

Robbing of the stone from the sluice access platform outside the south wall left the foundations of the mill in a poor state. It is likely that this happened in the 1960's while the Mill Pool was being infilled as a Caradon District Council rubbish dump.

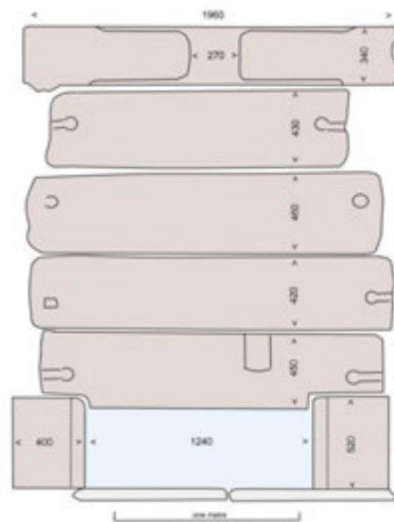

Details of the Sluice Blocking S3 in the outside face of the West wall. The lintel is a re-used 16th century window sill with a seating for a mullion. The main blocking slabs are probably capping stones from the local quay and Mill Pool walls. The upper stones are however also recycled 16th century material, details of which could be seen on the inner faces. The carefully shaped stones to take sluice boards sit on the stone paved floor of the sluice channel. This was the only point on site where the bottom of the sluice channel was accessible and measurements from this have been projected to establish the levels in other channels.

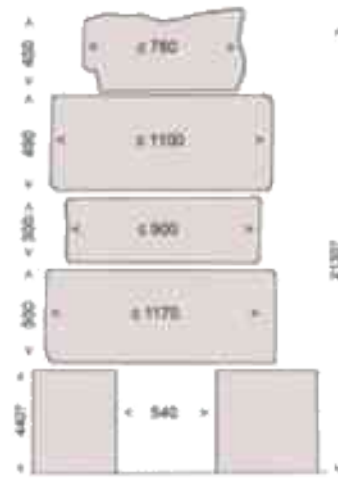

The granite blocking of Sluice 2. This small sluice which was probably part of the 16th century mill has rather less elaborate sluice board stones at the base but no lintel over the blocking

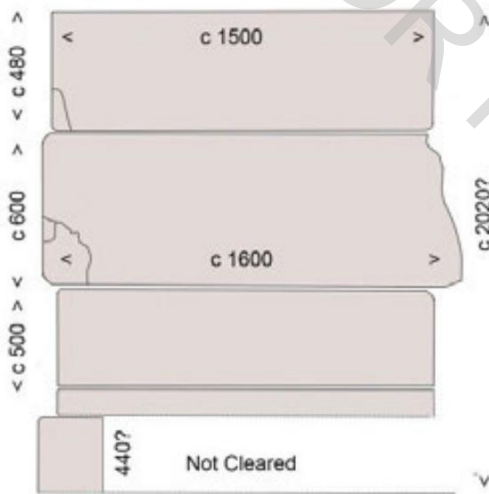

The granite blocking of 19th century sluice S5: this blocking is also made up of granite slabs which may have been capping stones

7.6 Phase 5: 21st century

Removal of the remnants of the flooring, and the first floor beams to storage began in 2010 when the present owner began renovation work and continued into 2011 when the building was gutted prior to restoration.



RAVINE HISTORY GROUP 2017

*Insworke Mill from the east in June
2011*

Looking south



RAMSEY HISTORY GROUP 2017



Looking north with roof being removed

Looking north with roof and all internal timbers



North east corner

removed . Lower walls part plastered for tanking.



Detail of Doorways D4 above and D3 below showing steel lintel and re-used mill lintel. Looking north



South east corner

8. DISCUSSION & INTERPRETATION OF INSWORKE MILL by Martin Watts

8.1 Introduction

The footprint of the surviving building of Insworke Mill, which archaeological investigation has confirmed dates from the late 16th century, is some 19.5m north-south by 7.5m east-west. By comparison with other mills of this period (of which few surviving examples have been identified) and other tide mills, this is relatively large. The tide mills at Beaulieu and Eling, in Hampshire, which are of medieval foundation but were both rebuilt in the 18th century, for example, have basic plan dimensions of 13m by 6.2m and 12.9m by 7.0m respectively. It is apparent however that all these mills were built as multiple mills, in other words, having more than one waterwheel and one set of milling plant. This also reflects the use of tidal water, as the pond that forms the reservoir provides, within the limitations of the tidal range, a given amount of water that can be used for any milling period. Therefore by increasing the number of waterwheels at the site, this potential can be better exploited.

There is also an interesting local parallel to Insworke Mill in the former tide mill nearby at Antony Passage in Saltash parish. This was the late medieval manor mill of Trematon, referred to as 'Salt-emyll' in 1462-3 (Michell Whitley 1925, 94). The surviving building bears a date stone of 1613, which indicates a rebuilding phase shortly after the construction of Insworke Mill. According to Rex Wailes at Antony Passage Mill 'There were two sluices and four wooden wheels about 12 ft. diam. by 3 ft. wide, driven by water from an 8½ acre pond.' (Wailes 1956, 15). For comparison, the area of the tidal pool at Millbrook was about 16 acres (6.5ha. Tithe Award, 1841), so almost doubling the potential water available to work Insworke Mill, although this would depend to a certain extent on any differences in tidal flow between the two sites and also the head of water that could be utilised.

8.2 Tide mill operation

In 1602 Richard Carew of Antony gave a contemporary description of local tide mill operation:

'Amongst other commodities affoorded by the sea, the Inhabitants make use of divers his [sic] creeks, for griste-mills, by thwarting a bancke from side to side, in which a floud-gate is placed with two leaves: these the flowing tyde openeth, and after full sea, the waight of the ebbe closeth fast, which no other force can doe: and so the imprisoned water payeth the ransome of dryving an under-shoote wheele for his enlargement.' (Carew 1769, 27).

Tide mills were usually built on sites with a moderate tidal range, in creeks and estuaries sheltered from the destructive waves and storms of the open sea (Jones 1986, 125). Water was stored in a large, shallow artificial pond, created by damming a tidal creek or building a wall to enclose an area on one side of a creek, as at Insworke. Sluice gates built into the dam or pond wall were pushed open by the flow of the incoming tide and, as the tide turned, the gate would close and be held shut by the weight of water in the pond. At high tide, and for a given period on both sides of high water, the waterwheel or wheels in the mill would be partially submerged. Once the tide had ebbed sufficiently for the water level on the downstream side to fall well below the wheelshaft, however, the miller would open a sluice or penstock behind the wheel, to let water onto the wheel and run the machinery.

The waterwheels used in tide mills were generally undershot, or very low breast-shot, water being directed under a sluice or penstock onto the floats. As the water level in the pond fell and the tide rose on the downstream side of the mill, the wheel or wheels would become back-watered (tidally impeded) and gradually lose power. The miller's working hours therefore depended on the time of the tide, which would give one short, but predictable, working period in each tidal cycle of about 12

hours 25 minutes. At many sites it is also apparent that the salt water captured in the tidal pond was supplemented by a freshwater supply and the pond would obviously hold a greater depth of water on a spring tide than on a neap.

At Insworke Mill the principal tidal gates were close to the south end of the mill and the opening for them is visible to the left of the mill on Rex Wailes's photograph of the downstream elevation. From later map evidence there was a second gate, probably used also as a spillway, to regulate the pond water depth by allowing excess water to flow over the top of a gate or cill, further to the west, about half way along the wall that formed the south-east side of the pond (see O.S. map 1912).

8.3 Technical background: review of published sources

Between 1936 and 1938 a survey of tide mills in England and Wales was carried out by Rex Wailes. He visited 23 mills and summarised his findings in a paper which was first presented at the Institution of Mechanical Engineers, London, in 1938. It is unfortunate that only a brief summary combining the technical details of all the mills he visited was published and the entry for Insworke or Millbrook Mill is, in hindsight, not particularly informative:

'Millbrook Mill on Millbrook Lake ceased working before the war of 1914. It had two wheels each driving two pairs of stones and bears on a stone the date 15 + 18 [sic] with a cable moulding surround, and above is another: REBUILT IN L 1801 C. It is now a coal store and its stone walls are roofed with corrugated iron.' (Wailes 1956, 15).

Some pencilled field notes made by Rex Wailes when he visited Insworke Mill in July 1937 were found by Alan Stoyel.¹ Although brief, these give a little more information than his published note:

*Pond as barge repairing & shipbreaking yard.
Millbrook tide mill. stone '1598' & above 'REBUILT IN / ? 1801 C'
Now a coal store.
Starts carry the float backing board, tangential to rim. Stopped before
war. 2 wheels, 4pr. stones. Use Welsh stones, best granite also used.*

These notes suggest that the 1518 date which appeared in his published survey may have been the result of a typographic error but, more importantly, imply that at least one waterwheel was still in place in 1937. The description of the 'starts' and 'float backing board' suggest that only the outer part of a wheel (or wheels) was visible and it is relevant to note that no dimensions appear to have been taken by Rex Wailes, as was usual where machinery survived. As there is no mention of Insworke Mill in the technical summaries of each element of the working parts of the 23 tide mills that were visited and, as only two exterior photographs taken by him have been traced, it is indeed possible that he was unable to gain access to the interior of the mill. The addenda to the survey, which was published in booklet form in 1956, contains only the following note, supplied by Miss E.M.

Gardner: *'Millbrook Mill. Now used as a repair shop for steamers.'* (Wailes 1956, 31).

A recollection taken from an oral history account notes that:-

'At one time it [Insworke Mill] had four waterwheels but three are remembered two large ones about fourteen feet across and one small one for auxiliary lifting to the second or third storey.' (Harris 1963, cited by CGB). In 1971 it was noted that:-

'It [Insworke Mill] is now a boat-building works. Inside, the three original floor positions remain but the sack-hoist pulley is the only remnant of the milling machinery. The millpool was filled in as a refuse dump by St German's RDC in 1966-7.' (Minchinton and Perkins 1971, 18). No evidence of the sack hoist was found during the recent survey.

8.4 Development of Mill Layout

The lack of documentary information concerning the layout of the waterwheels and machinery in the first phase is unfortunate, but some attempt at a reconstruction can be made, based on the recent archaeological investigation.

Four sluices or waterways through the basement level of the mill have now been partially excavated and recorded. It is feasible that each of these housed a waterwheel, although whether all four were in use at the same time remains uncertain. The four waterways are of different widths and there is clear evidence of different phasing, for example the enlargement of S1 to become the wider S5.

From the evidence of the lintel surviving on the exterior east elevation, S1 was originally similar in width to S2 and probably original to the building of the mill. There is no apparent symmetry with the positioning of the four waterways through the building, however, which can be seen in some other tide mills where the waterwheels are internal, such as at Eling, Hampshire, although this dates from a later period. The former S1 and S2 are roughly comparable in width to S4 and all have (or had) flat granite lintels on the downstream (east) elevation. S3 is over twice the width of these channels and has an arched opening on the downstream side. It is possible that this channel may originally have contained a waterwheel or it could have simply been a spillway, providing a readily accessible means for the miller to control the water flow and level in the millpond.

8.4.1 16th Century

Evidence from elsewhere would indicate that when Insworke Mill was built in the late 1590s, each of its waterwheels (whether 3 or 4) would have driven only a single pair of millstones. There are two options for the form of this drive: the medieval/early post-medieval arrangement is for a pair of millstones to be driven directly by a pair of gears, as shown in Figure 1. Before the end of the 16th century, however, the so-called 'treble mill' is first recorded, the earliest known reference to which comes from Devon (Watts 2002, 120). Using three additional gears (hence 'treble mill'), a second pair of millstones could be driven by the same waterwheel (Figure 2a). The second pair of stones was of smaller diameter than the pair driven directly by the pitwheel, because the additional gearing increased the speed of rotation.

This layout does not appear to have been adopted to any significant extent until later in the 17th century, however, at least partly due to the limited power capabilities of contemporary timber waterwheels, and narrow undershot wheels, such as would have been used at Insworke, are unlikely to have developed enough power to drive more than a single pair of stones each. However, there are examples known from both documentary sources and fieldwork in Devon and Cornwall of treble mill gearing being used to drive only a single pair of millstones (Figure 2b). The advantage of this was simply to increase the speed of rotation of the runner millstone, in order to perform more work. This would certainly be advantageous in a tide mill, where the milling period was relatively short and the rising tide would impede the waterwheels and slow them down. With regard to this layout, a further consideration is the possible pits on the upstream north sides of both S2 and S4, which were revealed during the excavation of the ground floor. Although these features could not be fully investigated, they may be fragmentary evidence of gear pits, in which case it would seem that the gearing layout shown diagrammatically in Figure 2b would form an appropriate interpretation. A possible layout for the waterwheels and millstones in the late Tudor mill is shown in Figure 4.

8.4.2 18th and 19th centuries

The spurwheel drive, which became the most dominant form in English water-powered corn mills, although illustrated in the 17th century, was largely an 18th century development, and appears to

have been the arrangement recorded in the c.1800 rebuild of Insworke Mill (Figure 3). From the estimate of cost for repairs (DRO 96M/Box 88/11), there was a waterwheel driving two pairs of French stones, for milling wheat for flour, a second waterwheel which drove the barley mill, presumably grinding animal feed or possibly malt for brewing, and a third waterwheel which drove bolting mills, for separating fine flour from meal, and the sack hoist. The waterwheels and machinery at this time were largely of timber construction, with iron gudgeons (shaft bearings), iron 'bonds' – bands or rings to bind the ends of timber shafts – and iron fastenings. It is of note that the third wheel drove an upright shaft and that the drives to both the bolting mills and the hoist were taken off by gearing, rather than belts and pulleys as was usual later in the 19th century. It is also of interest that this document is a record of repairs rather than complete replacement of the machinery, and thus the mechanical layout it reflects must already have been in existence.

The recollection cited above (Harris 1963), which states that there were two large waterwheels and a smaller one for working the hoist, confirms the early 19th century arrangement. It was not unknown for tide mills to have a secondary power source for operating a hoist, so that grain and meal could be moved in preparation for milling and dressing when the tidal conditions prevented the main machinery from running. Beaulieu Mill had a manually-operated hoist, while hoisting equipment in the large tide mill at Bishopstone, Sussex, was wind-powered (Stidder and Smith 1997, 40). It is feasible that a smaller diameter waterwheel in Insworke Mill, perhaps with its shaft set higher, would have worked for a longer period between tides than the main waterwheels that drove the millstones. The probable position of this wheel is considered below (Figure 5).

Rex Wailes noted that there were latterly two waterwheels and implied that each drove two pairs of millstones, Welsh (conglomerate) and granite being used for these. Examples of both types of mill-stone survive behind the Mill House to the north of the mill. The fate of the two pairs of French stones and the single stone for the barley mill referred to in the c.1800 estimate is unknown, although there are a number of fragments of French burr built into the upper walls of the mill and also two granite centres from built-up stones (see millstone catalogue and discussion section 6).

To drive two pairs of stones, the waterwheels would need to be more powerful than the original ones, which implies that the final layout was with two larger diameter wheels in the wider sluiceways, S3 and S5. If a smaller wheel did survive to work the hoist, then this was almost certainly to have been located in S4, as one of the principal floor beams, J2, restricts the clear width above S2 (Figure 5).

From the final layout of the building, as seen in cross Section, it would appear that the millstones would have been set up on hurst frames standing above the ground floor – and highest tide level – but not at first floor level (Figure 6). The first floor principal beams showed no evidence of mortises for the heavy horizontal timber framing (stone beams) that would have been needed to carry millstones (see record drawings) and the height of the first floor above the pit gear is too great. From the lack of any structural evidence in the form of beam bearings in the external walls, the hurst frames appear to have been free-standing above the ground floor, a layout recorded by Rex Wailes in the tide mill at Beaulieu, Hampshire and, more significantly, at the nearby Antony Passage and Wacker mills.

Again it is unfortunate that only the layout of Beaulieu Mill was illustrated in his published paper. At Beaulieu the top of the hurst was about 1.2m or so over the floor, which gave room for a sack under the meal spout. The floor would only have been wet on a very high spring tide, and when the tide was high no milling would be done. A raised floor, above highest tide level, was subsequently put in on top of the original floor at Beaulieu after the mill stopped grinding. Generally about 1.1m

clearance is needed under a spout for a sack, but in many older mills the meal spout discharged into a meal bin or ark, and the meal was then shovelled out into sacks. Mr Jak's statement refers to lines and crooks which were probably for holding and supporting open sacks, so it would appear that meal arks weren't used at Insworke, which is of interest in itself. Perhaps they were not usual in tide mills, because of the potentially wet environment, and that once milled the product was either taken away or hoisted for storage in the dry on the first floor.

The positions of the last working millstones can be conjectured, but the only physical evidence for their location are lifting rings on the first floor beam B5, from which hoisting tackle would have been slung to raise the runner stones for dressing and maintenance.

The remains of timber frames F1, F2 and F3, built into the internal west wall of the mill at ground floor level above the sluiceways S5, S3 and S4 appear have been to accommodate the penstock (sluice) controls for the three waterwheels. This framing would have formed a recess for clearance for the penstock or sluice post – the timber spine to which horizontal boards forming the sluice gate were fixed – when the gate was raised to run the wheel. The lack of similar timbers in the wall above S2 appears to confirm that this channel was not used to house a waterwheel in the final working phase of the mill.

8.4.3 20th century

After the mill stopped working the main openings in the west wall to S3, S2 and S5 were blocked externally, re-using substantial dressed granite blocks, and the pond area to the west was back-filled. The original function and location of these blocks is uncertain; some have square holes near their ends, which suggests they were laid horizontally end to end and held together with iron dogs. They may therefore have been used as coping stones on the top of the tidal pond wall. The two blocks forming the sides of the opening at the bottom of S3 have vertical slots cut into them, to locate a sluice gate or stop boards in order to stop or reduce water flow through the channel.

The only other feature that can be directly connected with the working parts of Insworke Mill is the substantial dressed granite block, found on the edge of the tidal creek to the south of the mill. This is identified as a bearing block which carried a horizontal bearing, most probably for a waterwheel shaft.

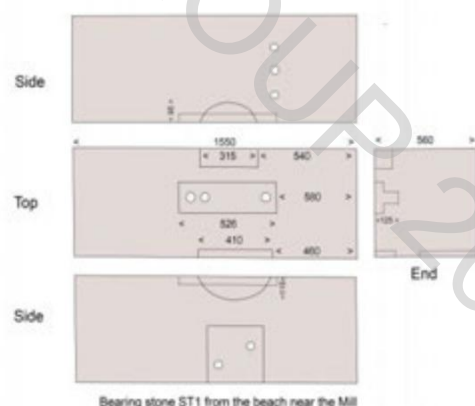

An interesting feature is that there are curved recesses in the tops of both side faces and it would appear that either the block was re-used or that it sat on the dividing wall between two of the waterways and carried the outer bearings of two wheelshafts, which were of different diameters.

There is, however, only evidence for fixings for a single bearing pedestal in the centre, although this does not necessarily preclude its use to carry two bearings.

8.5 Ancillary machinery

While the basic layout of the waterwheels and millstones can be conjectured, no physical evidence for secondary or ancillary machinery, including the sack hoist, was found during the recent survey. In the 1772 advertisement to let (*Sherborne Mercury* 6 January 1772 – see above) Inswork Mills (note plural, implying more than one waterwheel and set of machinery) are described as ‘Water Greist Mills’. Grist has a number of definitions, including the action of grinding and also the grain sent to a mill for grinding, but most relevant here is the west country usage of the term to describe a mill used for grinding small quantities of people’s own corn (Elworthy 1886; Wright 1898-1905). The mill thus provided a local service, generally following the later medieval tradition of grinding small parcels of grain that individual customers brought to the mill as required, and paid a toll, a proportion of the grain, for the grinding service.

From the early 19th century there is documentary evidence that Insworke Mill was used for the production of flour. In the estimate of c.1800, two pairs of French millstones were recorded, the favoured type of stone for grinding wheat for flour, and bolting mills are also referred to (DRO 96M / Box 88/11). Gorge Jak’s lease of 1838 (WDRO 68/21) is also of interest in that it lists several relevant pieces of equipment, including a *Smut machine fan &c*, for cleaning grain before grinding, and a *Flower Machine with Two Cylinders*, presumably a double machine for dressing fine flour and other grades from the meal produced by the millstones, perhaps the bolting mills referred to earlier, or their successors (Watts 2008, 25; 40-2). These pieces of machinery would most probably have been located at first floor level, fed by spouts from the bin or storage floor above and driven by gearing from the third waterwheel. There is also reference to a *Jumper*, a reciprocating sieve that would most likely have been fed directly from the meal spout of one pair of millstones.

The 1855 reference to a baker and flour factor in connection with Nicholas Parsons of Millbrook, miller, is further evidence that the mill was still producing flour in the middle of the 19th century (WDRO 68/66, cited by CGB).

On the 1869 1:10560 Ordnance Survey map (Cornwall sheet 055) the mill is labelled ‘Inswork Mill Flour’. It is likely, however, that any significant trade in flour would have ceased by the 1880s, when significant changes in flour milling technology took place. By the end of the 19th century little wheat flour was milled on traditional millstones driven by water power (for a summary see Watts 2008). It is likely that the waterwheels and millstones were used latterly for grinding animal feed and the French stones may well have been removed and sold off before the mill finally stopped work in the early 20th century.

8.6 Acknowledgements by Martin Watts

I am grateful to Alan Stoyel for the loan of prints of Rex Wailes’ photographs and for a copy of his notes on Insworke Mill; to Nigel Wilkins, English Heritage, for searching the photographs held by the National Monuments Record; to David Plunkett for information on Eling Mill, Hampshire; and to Sue Watts, for useful discussion and her help in compiling these notes.

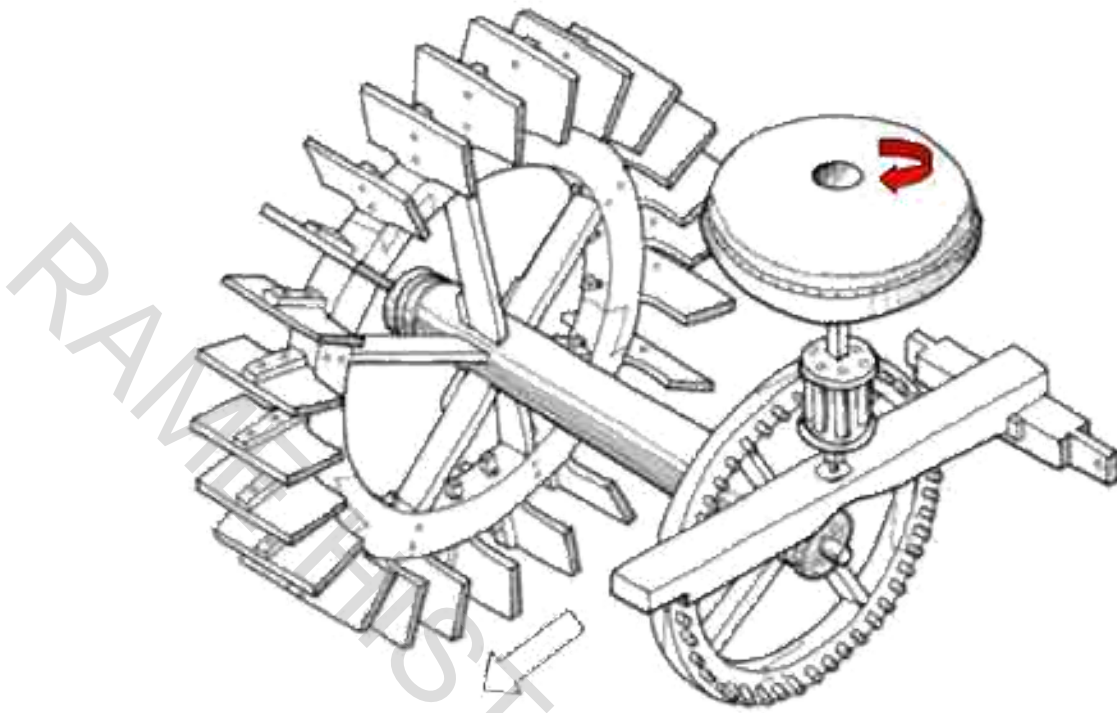

Figure 1: Late medieval/post-medieval undershot waterwheel driving a single pair of millstones. A general reconstruction based on documentary and archaeological evidence.

Blue arrow indicates direction of water flow; red arrow indicates that runner stone turns clockwise (Martin Watts)

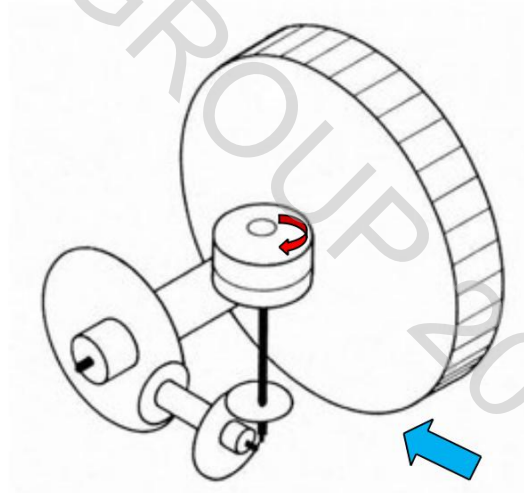
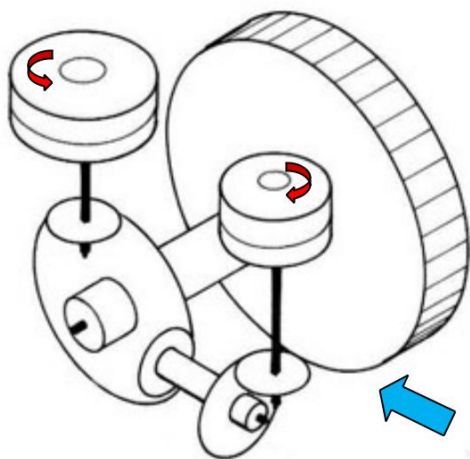

Figure 2a: 'Treble mill' drive to two pairs of millstones

Figure 2b: 'Treble mill' drive to a single pair of millstones

RAME HISTORY GROUP 2017

Note direction of water flow and millstone rotation. The millstones would be located to be driven off the loaded side of the wheel, for mechanical efficiency

RAME HISTORY GROUP 2017

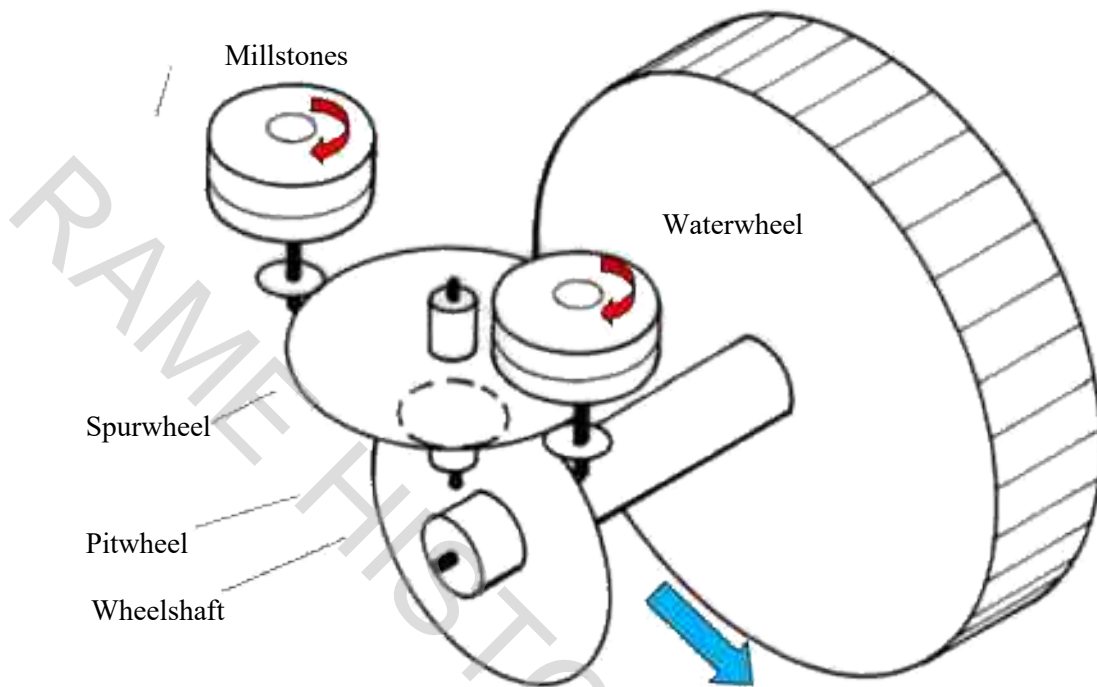

Figure 3: Diagrammatic representation of spurwheel drive to two pairs of millstones. Blue arrow indicates direction of water flow; red arrows indicate that both runner stones turn clockwise

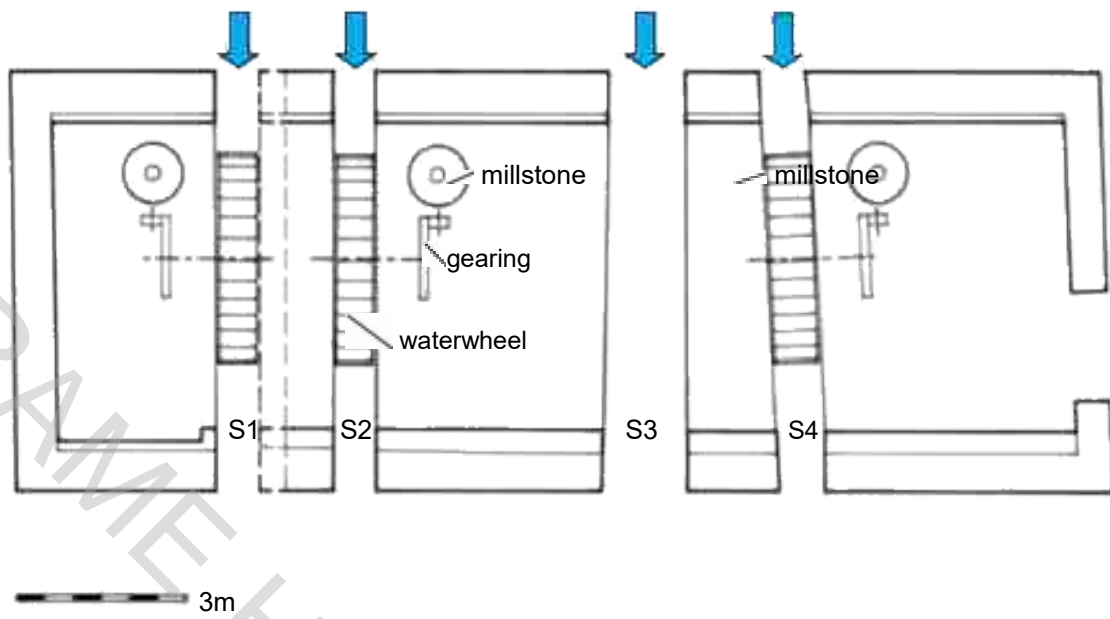

Figure 4: Insworke Mill. Conjectural layout of late 16th century mill, with three waterwheels and channel S4 as a spillway

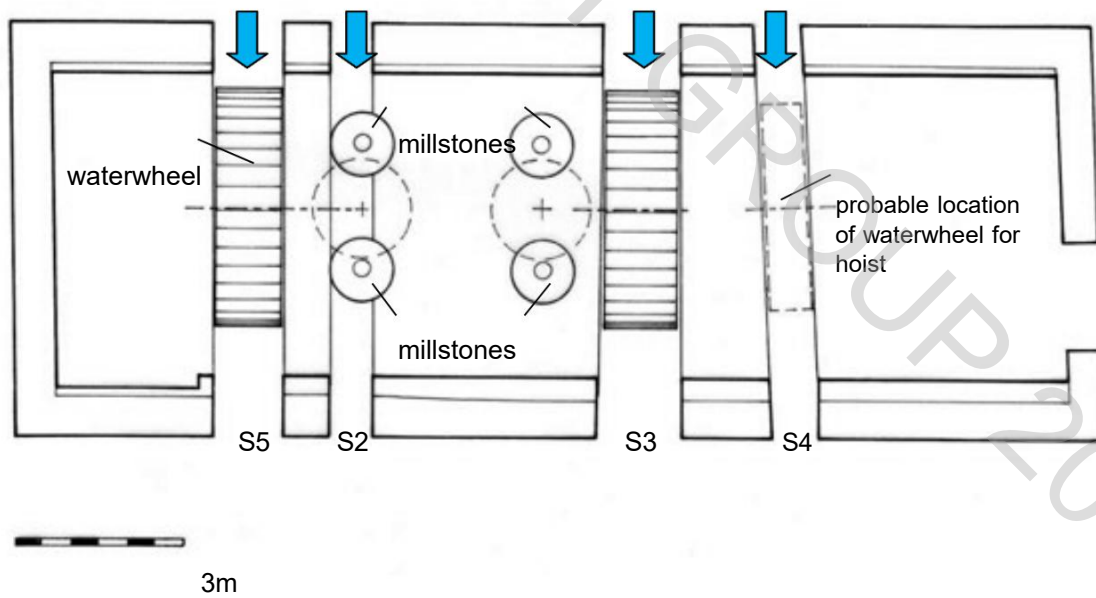

Figure 5: Insworke Mill. Conjectural layout of late 18th – early 19th century mill

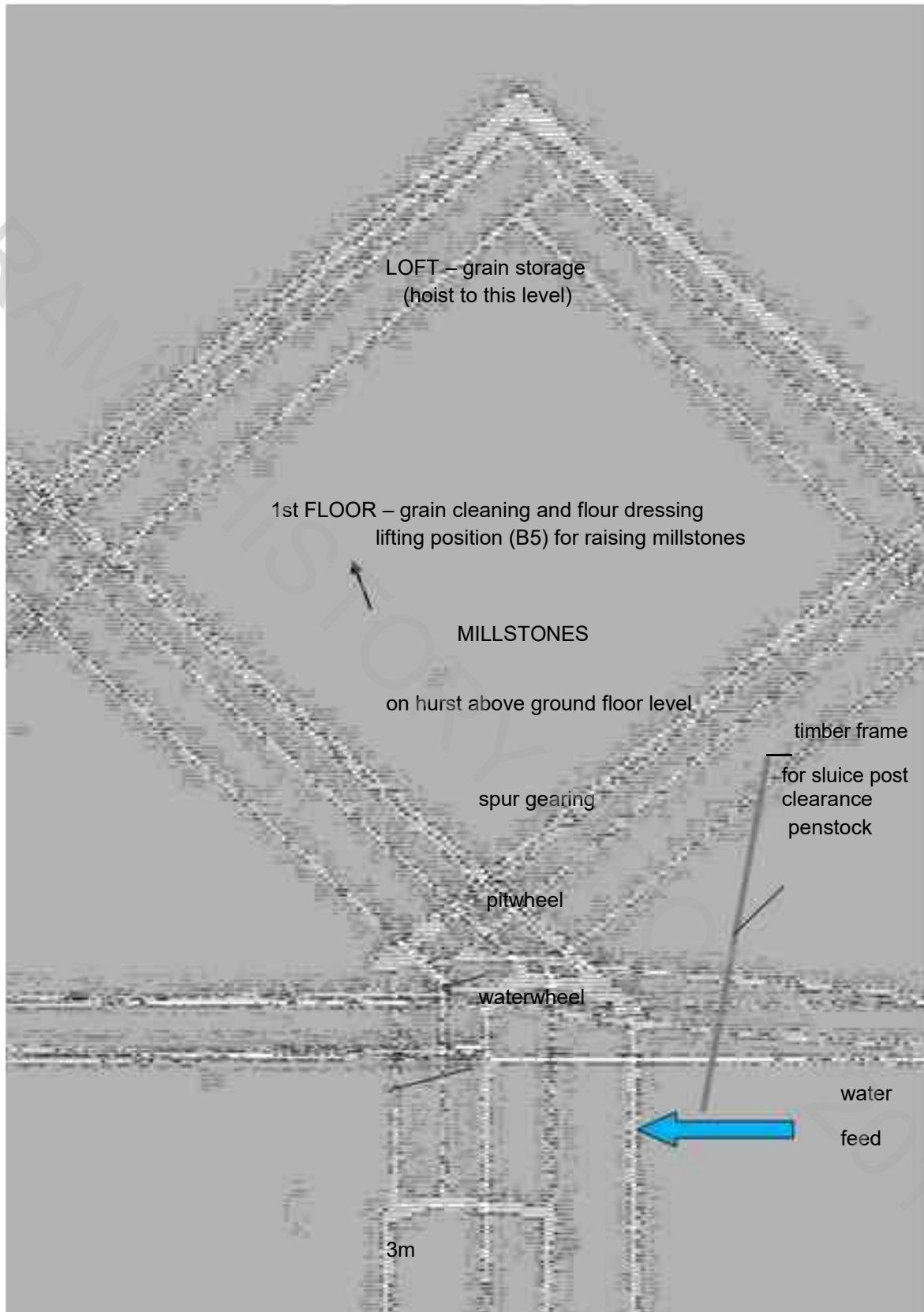

Figure 6: Insworke Mill. Section through mill, showing possible layout of final phase machinery

9. BIBLIOGRAPHY

- Carew, Richard. 1769: *The Survey of Cornwall* (first published 1602)
- Ellworthy, Julie. 1994: Millbrook Brick by Brick; a pictorial trip down memory lane
- Elworthy, William. 1886: West Somerset Word Book
- Fox, H.S.A. 1994: The Millstone Makers of Medieval Dartmoor. *Devon and Cornwall Notes and Queries* 37.5, 153-7
- Gaskell Brown, C. 1980: *A Guide to the Industrial Archaeology of Plymouth & Millbrook*, 36-43
- Graham, A., Draper, J. & Watts, M. 2005: *The Town Mill Lyme Regis: Archaeology and History AD1340-2000* (Town Mill Trust, Lyme Regis)
- Harris, G.L. 1963: *Essays and Notes on the Rame Peninsula* (typescript in Torpoint Library)
- Jones, David H. 1986: An Analysis of Tide Mill Operation. *Transactions of the Sixth TIMS Symposium, Ghent 1985*. (The International Molinological Society, Belgium), 123-36
- Kittridge, Alan. 1984: *Passenger Steamers of the River Tamar*
- Lysons, S & D. 1814: *Magna Britannia: volume 3: Cornwall*, 72-78
- Michell Whitley, H. 1925: The Manor Mill of Trematon Castle. *Devon and Cornwall Notes and Queries*, 13, 94-6
- Minchinton, W & Perkins, J. 1971: *idemills of Devon and Cornwall* (Exeter Papers in Industrial Archaeology)
- Payne, Margery. 2007: *The History of Wacker Mill, Antony, SE Cornwall*. (Unpublished compilation: copy in Mills Archive, eading)
- Reynolds, J, 1970: *Windmills and Watermills*
- Robinson, R. 1991: Millstone Working on Brent Moor. *Devon and Cornwall Notes and Queries* 34.8, 333-4
- Russell, J. 1944: Millstones in Wind and Water Mills. *Transactions of the Newcomen Society* 34 (1943-4 and 1944-5), 55-64
- Stuart, Elisabeth. 1991: *Lost Landscapes of Plymouth - Maps, Charts and Plans to 1800*.
- Tangye, M. 1992: Decorated Mill-Stones. *Old Cornwall* 11.2, 66-9
- Tucker, G. 1973: Millstone Making in Gloucestershire. *Gloucestershire Industrial Archaeology Society Journal*, 6-16
- Tucker, G. 1977: Millstones, Quarries, and Millstone-Makers. *Post-Medieval Archaeology* 11, 1-21
- Vince, J. 1970: Discovering Watermills
- Wailles, Rex. 1939: Tidemills in England and Wales. *Trans Newcomen Society, XIX (1938-39)* 1-33
- Ward, O. 1993: *French Millstones. Notes on the Millstone Industry at La Ferté-sous-Jouarre* (The International Molinological Society)
- Stiider, D & Smith, C. 1997: *Watermills of Sussex, 1 – East Sussex* (Baron)
- Wailles, Rex. 1956: *Tide Mills*, Part 1 and Part 2 (SPAB, London)
- Watts, Martin. 2002: *The Archaeology of Mills and Milling* (Tempus, Stroud)
- Watts, Martin. 2008: *Corn Milling* (Shire Library)
- Wright, Joseph, 1898-1905: *English Dialect Dictionary*, 6 volumes

Other sources consulted:-

Ordnance Survey 1:10560, Cornwall sheet 055, 1869

<http://www.british-history.ac.uk/mapsheet.aspx?> (Date accessed 26 August 2011)

Magna Britannia: <http://www.british-history.ac.uk/report.aspx?compid=50614>
(Date accessed: 30 September)

<http://www.rameheritage.co.uk/>

<http://www.ramehistorygroup.org.uk/>

10. ACKNOWLEDGEMENTS by Cynthia Gaskell Brown

We would particularly like to thank Keith Bousfield who assisted through a hard winter with measuring, photography, scaling the heights to check the roof structure and date stones; and who provided proof reading skills for the report. Carl Newton's skills with computer drawing and additional photography were invaluable. Alan Kittridge and Roger Collins gave generous help locating historic photographs. We are most grateful to Alan Vaughan of the Mill House for providing access to his millstone collection. On site Peter Dunstone and David Paramour were the enthusiastic excavators of the evaluation trench; while the expert builder Barry Pringle and his assistant Ben Southern provided skilled and willing assistance during the exploration of the Basement and recording of the Building structure. Shipwright Chris ees gave useful guidance on timber identification and local knowledge provided by Peter Carne, ichard Crane, and Colyn Thomas was much appreciated. Phil Copleston of Cornwall Council gave most supportive professional advice.

11. DOCUMENTARY RESOURCES

1772 Mill advertised to let in the Sherborne Mercury, 6 January

1772 – 1795 Agreement between Humphry Hall, Esq John Inglett Fortescue Esq and William Bickford concerning the rebuilding of Insworth Mills & Dwelling House in the Parish of Maker in Cornwall (DRO, Exeter. 96M/Box15/15)

1798-1801 Kellow Mill and New Barn at Insworth, Millbrook (DRO, Exeter. 96M/ Box 88 /11).

Includes: *At Insworth Mills an estimate* for the new millwork and the reparing the old mill work belonging to the Right Honourable Lord Clinton by Mr Denston. *A plan of the Mill*, sixteenth scale

1809 Valuation of the Manor of Millbrook and Insworth for Lord Clinton (CRO Trefusis Papers X1147/1/10).

1815 Memorandum of agreement and lease, Insworth tide mills (CRO. TS/12, 13. Truro)

1838 (See 68/21 below) Statement of machinery in Insworth Mills to be sold by Mr George Jak to r Lewis Parsons of St Johns Mills, 16th September 1838

1839 Lease for 7 years, 29 August 1839

(DRO, Plymouth. Devon and Cornwall deeds Catalogue ref 68/20. Examined 26/08/08 by CGB)

Lease for 7 years

1. Rt Hon Baron Clinton of Heanton Satchville, Devon
2. Lewis Parson of Insworth Mills, Maker, miller
3. Nicholas Parson of St John mill

Messuage, tide water grist mill called Insworth Mill, Maker, with the Quay and machinery. Two fields called the Meadow or Mill green and the Mill Field or Kiln Park
Rent £75

1852: 1838 Lease for 7 years, 16 September 1852 :1838

(DRO, Plymouth. Devon and Cornwall deeds Catalogue ref 68/21. Examined 26/08/08 by CGB)

Lease for 7 years

1. Rt Hon Baron Clinton of Heanton Satchville, Devon
2. Nicholas Parson of Insworth Mills, Maker, miller
Property as above. Rent £64

Inside: statement of machinery in Insworth Mills belonging to Mr George Jak. With agreement to sell same to Mr Lewis Parsons of St John's Mills, 18 September.

Other records in Devon Record Office, Plymouth.

Devon and Cornwall deeds

68/33. 8 February 1716: Lands and tenements in Newport street late in the inheritance of Mathew Kellow, deceased. Examined 26/08/08 by CGB. No reference to Insworth in this document.

68/64. 3 May 1890: Notice of assignment of insurance policy from John Price of Millbrook, joiner to John Parson of Insworth Mill.

68/66. 8 March 1855: 1. John Pearce of Millbrook, baker. 2. Joseph Crossing of Plymouth flour factor, Nicholas Parsons of Millbrook, miller (bankruptcy of John Pearce). Examined 26/08/08 by CGB.

Note on historic photographs of the mill

Many of Rex Wailes' photographs are deposited in the National Monuments Record, part of English Heritage, in Swindon. A search of the NMR collection carried out in June 2011 produced only one image of Insworth/Millbrook Mill, of the east elevation. The material rescued by Alan Stoyel after Rex Wailes's death in January 1986 was deposited with the Science Museum, London, and remains uncatalogued; some items were also deposited in the Mills Archive, Reading (Alan Stoyel, pers comm to Martin Watts).

12. APPENDICES

12.1 Trefusis Family

Lysons, S and D 1814, Magna Britannia: volume 3: Cornwall (1814), pp. 72 -78. 'General history: Nobility, earldom and ennobled families'

<http://www.british-history.ac.uk/report.aspx?compid=50614> Date accessed: 30 September

“Trefusis, Lord Clinton and Say. — Although the ancient Cornish family of Trefusis did not acquire the barony of Clinton and Say till 1794, we are aware that his barony stands fourth in the list of English barons. The Trefusis family is to be traced, as resident at Trefusis, in Milor, the seat of their descendant Lord Clinton, four generations before 1292. During the course of twenty-three descents, they have married the heiresses of Delechamp, Treviados, and Balun; and coheiresses of Martin, Halep, Tresithney, Colan, Trevanion, Gaverigan, and Cotton; besides the match with Rolle, through which the barony of Clinton and Say was acquired, Francis Trefusis, Esq. having married Bridget, daughter of Robert Rolle, Esq., of Heanton, who had married Arabella, the elder daughter and coheir of Theophilus Clinton, Earl of Lincoln. The barony of Clinton and Say being in abeyance between the coheirs of this arl, was given by King George I, in 1721, to Hugh Fortescue, son and heir of Hugh Fortescue, Esq., of Filleigh, in Devonshire, by Bridget, sole heiress of Hugh Boscawen, of Tregothnan, who had married one of the coheiresses of Clinton, and who in 1746 was created Baron Fortescue, and Earl Clinton. On is Lordship's decease without issue, in 1751, the barony of Clinton and Say (fn. 3) devolved to Margaret, only daughter of Samuel Rolle, Esq. (only brother of Bridget above-mentioned), then recently become the widow of Robert Walpole, second Earl of Orford. On the death of her son George, Earl of Orford, in 1791, this title was claimed by George William Trefusis, Esq., the descendant, in the fourth generation, of Francis Trefusis and Bridget Rolle. The claim was allowed by the House of Lords in 1794. Robert Cotton St. John Trefusis, the present Lord Clinton and Say, succeeded his father in 1797, being then a minor. Trefusis house is still the family-seat.

George, Earl of Orford, in 1791, this title was claimed by George William Trefusis, Esq., the descendant, in the fourth generation, of Francis Trefusis and Bridget Rolle. The claim was allowed by the House of Lords in 1794. Robert Cotton St. John Trefusis, the present Lord Clinton and Say, succeeded his father in 1797, being then a minor. Trefusis house is still the family-seat.”

12.2 Agreement 1795

Insworke Mill Document Transcript: Devon Record Office: 69M/ Box 15/15 Rolle and Clinton Family.

Agreement between Humph^y Hall Es^q & Jn^o Inglett Fortescue^{Esq} & Will^m Bickford concerning the rebuilding of Insworth Mills & Dwelling house in the parish of Maker in Cornwall

Memorandum of an Agreement made and entered into the twenty ninth day of July one thousand and seven hundred and ninety five between Humphry Hall, John Inglett Fortescue Esquire of the one part and William Bickford of the parish of Maker in the County of Cornwall, Miller, of the other part.

Whereas the Right Honorable George William Earl of Coventry, the said Humphry Hall Ambrose St John sq, and the said John Inglett Fortescue Esq, Trustees for certain Manors and Lands of the Right Honorable Lord Clinton, by their Indenture of Lease bearing date the twentieth day of this instant July, Did demise and grant and let unto the said William Bickford All those corn or grist mills called Insworth alt Water Grist Mills together with the Millhouse and Garden thereto belonging situate on the salt water adjoining the spot of ground where Millbrook Old Brewhouse formerly stood in the parish of Maker and also the Fishing thereto belonging and all those two fields called Hillpark containing by estimate seven acres one rood and two poles or thereabouts and Hillgreen alias Millgreen containing one acre and half and thirty four poles (more or less) then in the possession of the said Willm Bickford,

To Hold to the said William Bickford his Executors Administrators and Assigns from the twenty fifth day of March last past for and during the full term and time of twenty on years under the yearly rent of **60£** and subject to diverse covenants and agreements therein contained and amongst others that the said Will^m. Bickford his Executors Administrators and Agt. shd. At his & their own costs and charges when and as often need shd. require repair amend & keep in good repair all & singular the said premises as well as Houses Walls Windows Coverings Doors Flood Gates Flood Hatches Wheels Cogs Rounds Alter boards Stirts all Brass & Iron work & all & every the Gates Barrs Stiles Hedges Ditches Gutters Fences & all needful & necessary repairs & amendments whatsoever the same being first put in good repair by the said Lord Clinton, as in & by this and in part recited Indenture of Lease, Reference being thereto had will more fully appear

And **Whereas** upon carefully and minutely examining the condition of the said Mills & Millhouse they have both been found to be in such a State of general Dilapidation & decay that it is utterly impossible to repair the same with any advantage to the Landlord or Tenant but the whole must be taken down & rebuilt And whereas the said Millhouse or Dwelling house at present stands so low that the same is frequently overflowed by more than two feet water in the ground floor to the great inconvenience & danger of the tenant & his Family,

Now **Therefore** the said Humphry Hall & Jn^o. Inglett Fortescue as such Trustees aforesaid do herby covenant and agree with said William Bickford his Executors Administrators & Assigns that the said Humphry Hall & Jno. Inglett Fortescue or the Agents for the said Lord Clinton shall & will

cause the said Mills & Millhouse or Dwelling house to be new built & erected in a strong and substantial manner & with as much dispatch as may conveniently may be & that the said Dwelling house shall be built and placed in an higher & better situation than the site of the old Millhouse for the accommodation of the said William Bickford & his family.

And the said William Bickford for himself & his Executors & Adms. Doth hereby covenant & agree with the said Humphry Hall & Jn^o Inglett Fortescue that for the Considerations aforesaid the said Will. Bickford shall & will advance all such monies as may be required in building the said dwelling house upon his being allowed 5 £ per cent for this sum until such money so advanced by him shall be pd. up or allowed out of the rent of the said premises or otherwise by the said Humphry Hall & Jn^o. Inglett Fortescue or the Agents for the said Lord Clinton & also that the said Willm Bickford shall & will at his own expence bring & carry all the materials to the spot whereon the sd. Dwelling house is to be built. & further that he the sd. W. Bickford shall & will likewise advance all such money as may be required for building the said Mills without any allowance for Interest whatsoever being repaid the same as soon as conveniently may be by the said H^y. Hall & J. Inglett Fortescue or the Agents for the said Lord Clinton by allowing such money out of the rent of the said

Premises or otherwise & also that the said W. Bickford shall & will at his own expence bring and carry all the materials which may be required for rebuilding the said Mills and also shall & will pay as an additional rent for the said premises during the remainder of the said time granted by the said in part recited Indenture of Lease at & after the rate of 6 ½ £ p cent for such money as shall be laid out & expended in & about the rebuilding the said Dwelling house & that after the said Mills and Dwelling house shall have been rebuilt as aforesaid. Then that the aforesaid William Bickford his Executors Administrators & Agts. shall & will keep the same in good & substantial repair ' in ' & throughout & during the residue & Remainder of the said term of 21 years

As witness our Hands

J. Inglett Fortescue
Humphry Hall

12.3 Estimate for New Mill work c.1800

Insworke Document Transcript DRO: 96M/Box 88/11

Estimate, n. d. but with other material dated 1800-01

At Insworth Mills

*An estimate for the New Mill work and the
Repairing the Old Mill Work belonging to the
Right Honourable Lord Clinton by M^r Denston*

<i>To one new main Oak Shaft to drive the 2 Mills -----</i>	<i>£ s d</i>
	<i>10 10 0</i>
<i>To One New Cogwheel to the Same</i>	<i>10 0 0</i>
<i>To One New pitt Wallow Nutt</i>	<i>4 12 6</i>
<i>To 3 New Oak arms to the water Wheel ----- and floats and Stirts and labour</i>	<i>4 10 0</i>
<i>To 2 new pillow blocks to the same</i>	<i>1 0 0</i>
<i>To 2 New Mill Hoops &c</i>	<i>4 4 0</i>
<i>To 2 pair of New french Stones ^{obtained for 27.6}</i>	<i>63 0 0</i>
<i>Dto to 1 New foot brass to the upright Shaft</i>	<i>1 3 4</i>
<i>Dto to 2 gudgeon brasses to the Double gear</i>	<i>2 2 0</i>
<i>Dto to one New spill foot brass</i>	<i>0 18 8</i>
<i>Dto to 2 New Inks of Iron work</i>	<i>3 3 0</i>
<i>Repairing the Spindles</i>	<i>1 11 6</i>
<i>To 4 Bonds to the main Shaft ^{old ones do}</i>	<i>2 2 0</i>
<i>To 2 New gudgeons to the Main Shaft</i>	<i>2 2 0</i>
<i>To Screw bolts to the pitt Wallow Nutt</i>	<i>0 12 0</i>
<i>To 2 Bonds to the pitt Wallow Nutt</i>	<i>1 10 0</i>
<i>To one New Tee gudgeon</i>	<i><u>1 1 0</u></i>
	<i>114 8 0</i>
<i>To Repairing the barley Mill Water Wheel</i>	
<i>feathering floats and Stirts</i>	<i>3 3 0</i>
<i>To A New Cogwheel to the same</i>	<i>10 0 0</i>
<i>To a New pitt Nutt to the same</i>	<i>1 12 6</i>
<i>To One New pillow block to the same</i>	<i>0 10 0</i>
<i>To one New gudgeon to the same</i>	<i>1 0 0</i>
<i>Dto to 4 Screw bolts to the Cogwheel</i>	<i>0 4 0</i>
<i>Dto to 2 New bonds to the pitt Nutt</i>	<i>0 8 0</i>
<i>Dto to 8 Screw bolts to the pitt Nutt</i>	<i>0 8 0</i>
<i>Dto to Nails for the water wheel</i>	<i>0 6 0</i>
<i>Dto to A New bin</i>	<i>0 7 6</i>
<i>Dto to 2 New gudgeon brasses</i>	<i>2 2 0</i>
<i>Dto to One New spill foot brass</i>	<i>0 18 8</i>
<i>Dto to One New french Stone</i>	<i><u>18 18 0</u></i>
	<i>39 14 8</i>

<i>Dto to One New water Wheel to the</i>	<i>£ s d</i>
<i>Bolting Mills and Sack tackle</i>	<i>12 12 0</i>
<i>Dto to A New shaft to the same</i>	<i>8 8 0</i>
<i>Dto to a New Cogwheel to the same</i>	<i>10 0 0</i>
<i>Dto to 2 New pillow blocks to the same</i>	<i>1 0 0</i>
<i>Dto to a New upright Shaft</i>	<i>2 12 6</i>
<i>Dto to a New flie wheel</i>	<i>4 4 0</i>
<i>Dto to 2 Spur Nutts and 2 pulleys</i>	<i>3 3 0</i>
<i>Dto to one New Bridge</i>	<i>0 10 6</i>
<i>To New build all the mill bed</i>	<i>42 0 0</i>
<i>To 4 Drawers and hatches</i>	<i>2 10 0</i>
	<i><u>87 0 0</u></i>

Brought over from the other side *£ s d*

<i>Dto 2 New gudgeons to the Shaft</i>	<i>2 2 0</i>
<i>Dto to 4 New bonds to the same</i>	<i>2 2 0</i>
<i>Dto to 4 Screw bolts to the Cogwheel</i>	<i>0 4 0</i>
<i>Dto to One tee gudgeon</i>	<i>0 18 0</i>
<i>Dto to One drift gudgeon</i>	<i>0 10 0</i>
<i>Dto to 4 Bonds on the upright Shaft</i>	<i>1 14 0</i>
<i>Dto to 4 Screw bolts to the flie wheel</i>	<i>0 4 0</i>
<i>Dto to 16 bolts for the Bolting Nutt and sack</i>	
<i>Tackel Nutt</i>	<i>0 16 0</i>
<i>Dto to Nails</i>	<i>0 10 6</i>
<i>Dto to 2 New gudgeon brasses</i>	<i>2 2 0</i>
<i>Dto to a foot brass under the upright shaft</i>	<i>1 3 4</i>
<i>Dto to a pair of Capland brasses to the Top</i>	
<i>of the upright Shaft And Iron Staple to the same</i>	<i>0 18 0</i>
<i>Dto to 2 pair of Capland brasses for the</i>	
<i>Bolting mills and Sack tackle</i>	<i><u>1 3 4</u></i>
	<i>14 7 2</i>
	<i>114 8 0</i>
	<i>39 14 8</i>
	<i><u>87 0 0</u></i>
	<i>255 9 10</i>

12.4 Plan of Mill with dimensions c.1800 Insworke Document. DRO 69M/Box 88/11

"The Mill: 62 feet by 24 feet waid: 18 feet high; walls 2 feet; sixteenth to a foot"



13. TREE RING REPORT BY ANDY MOIR

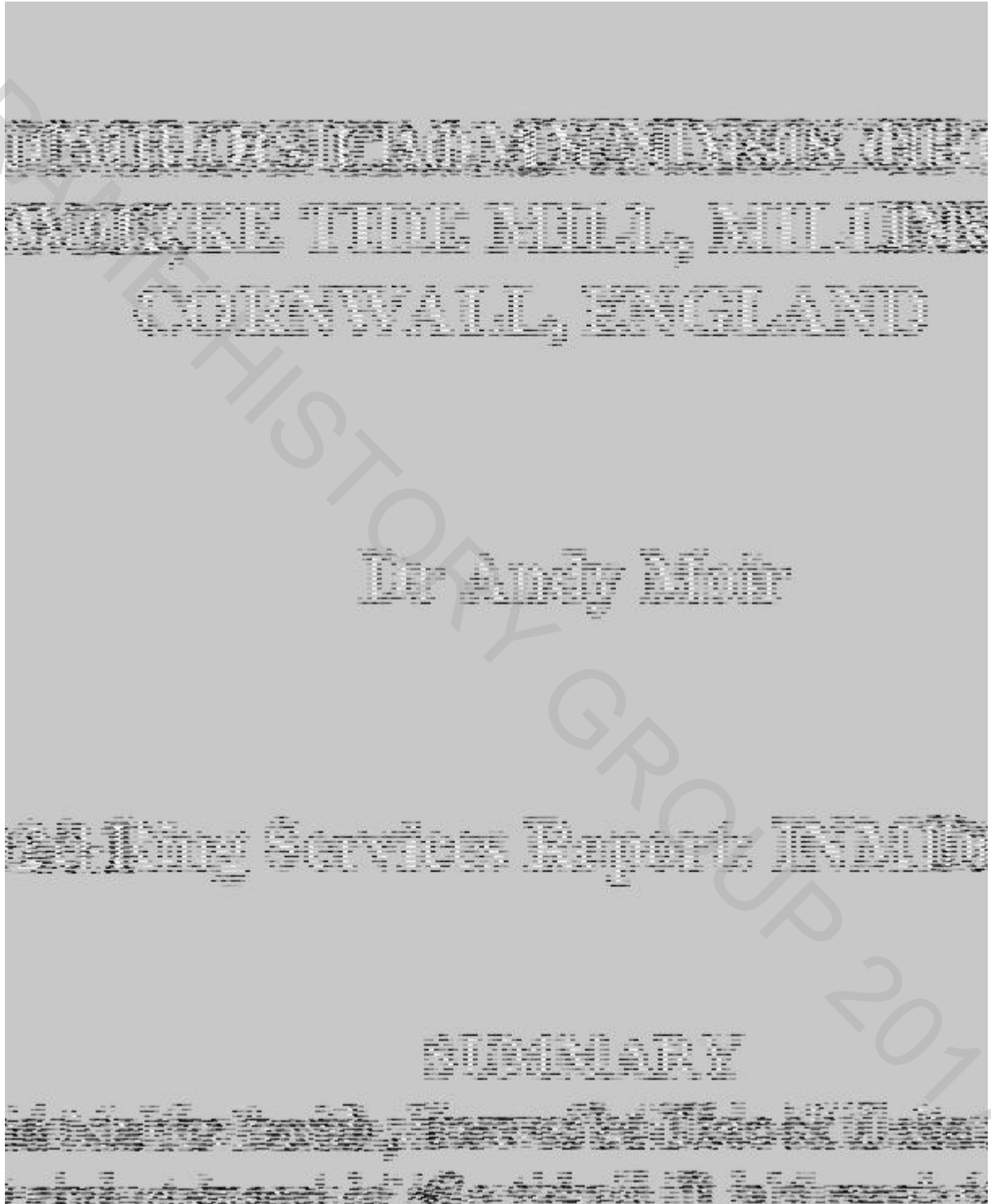



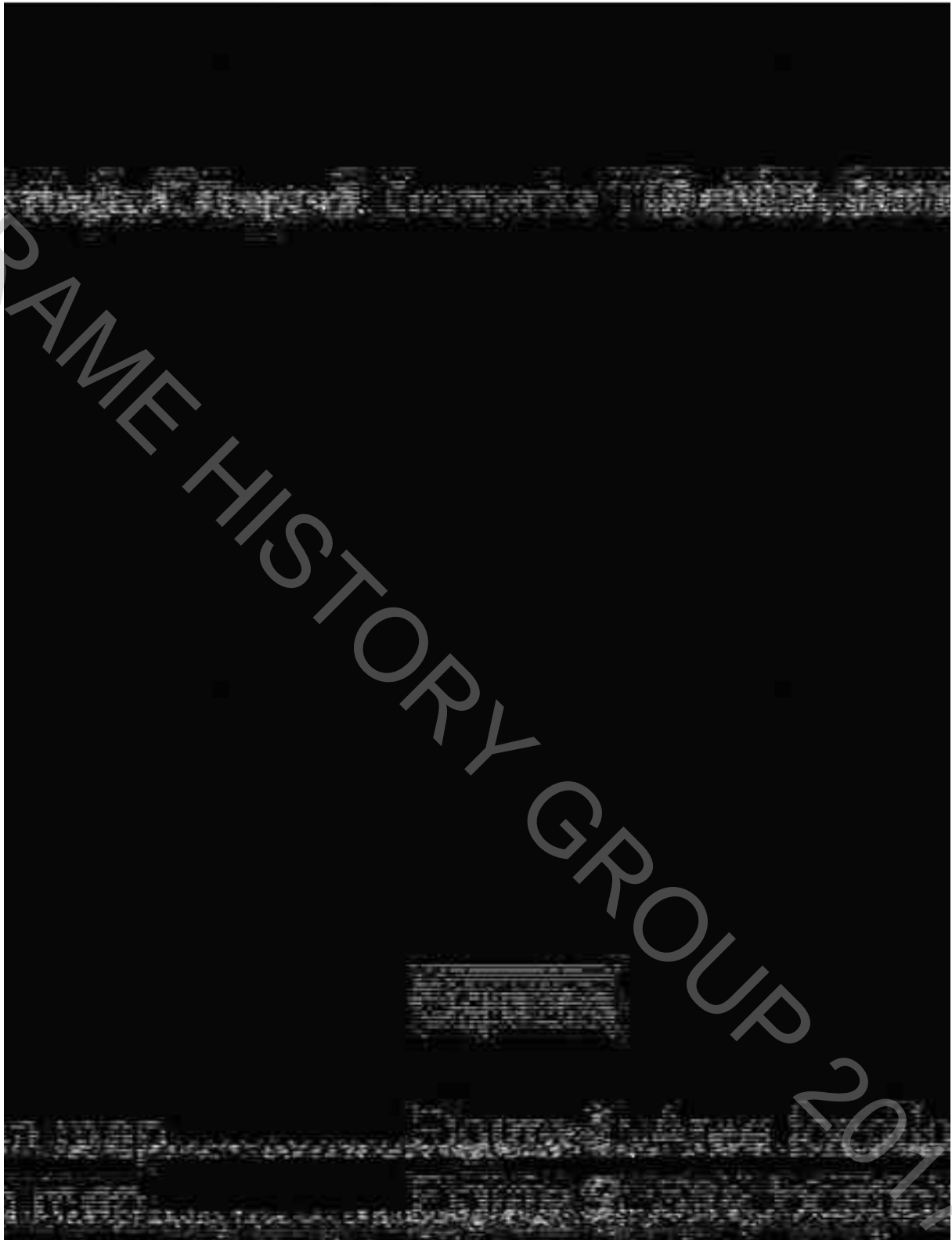

INTRODUCTION

There is an increasing interest in Britain's past as evinced by such television programmes as "Time Team" and "The House Detectives" which both promote and respond to this interest. More and more people wish to know precisely when ancient buildings were constructed in order to better understand the history of the land in which we live. However, although there is some ability to date a building on stylistic grounds, a precise date is rarely known except when there is a date-stone or documentary evidence.

The advent of dendrochronology (tree-ring dating) is changing this scenario, at least for buildings with timbers containing sufficient rings for analysis. The science is simple in concept. The width of a tree's growth rings varies from year to year, so that each series of years has a unique pattern of narrow and wide rings. We now know in detail the pattern of rings shown by oak trees in England for at least the last 2000 years, and there is some work in progress on other species. Small cores of wood taken from the structural timbers of a building show the pattern of rings laid down during the lifetime of the trees from which the timbers were cut. If this pattern is then compared with 'master chronologies' it is often possible to identify the felling date of the trees with astonishing accuracy. Where bark is present, it is possible to give a precise year, sometimes even the season of the year. We know that oak for building was almost always used 'green', (unseasoned, not having been felled and prepared until required), so construction dates can be determined in which we can place considerable confidence.

Figure 1: Area location map



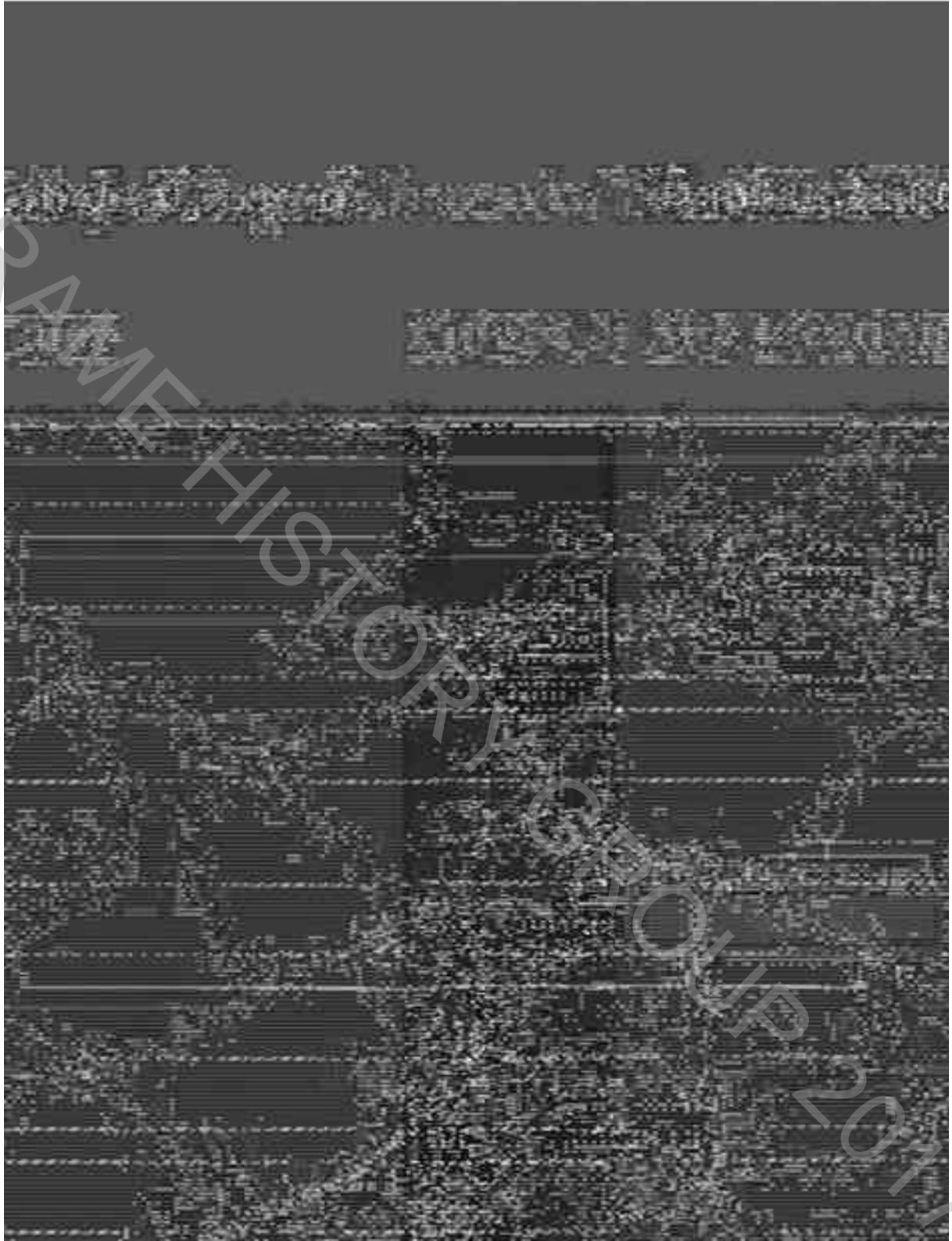

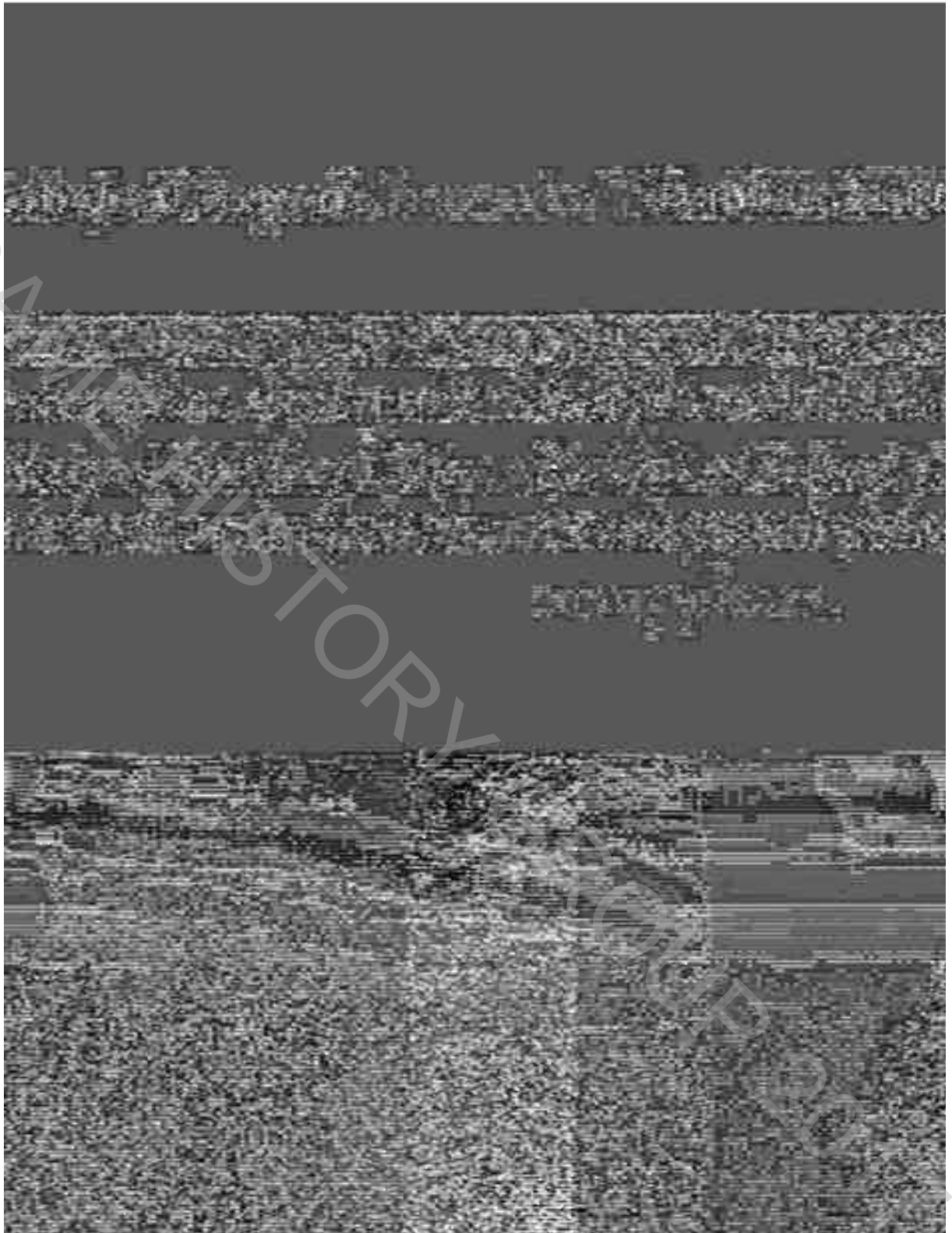



Dendrochronological Report: Inwornek Tide Mill, Millbrook, Cornwall

Cross-correlation algorithms are then employed to search for the positions where tree-ring series correlate and therefore possibly match. All statistical correlations are reported as t -values derived from the original CROST3 algorithm (Baillie and Pilcher 1973). A value of 3.3 or over is usually indicative of a good match as it represents the value of t which should occur by chance only once in every 1000 mismatches (Baillie 1982), and the higher the t -value the closer to congruency in the cross-matching. However, due to the remaining small risk of high t -values being produced by chance, all indicated correlations are further checked to ensure that corroborative high results are obtained at the same relative position against a range of independent tree-ring series. Visual comparisons of series are also employed to support or reject possible cross-matches and serve as a means of identifying measuring errors.

Timber Groups



A further element of the tree-ring analysis of buildings and archaeological assemblages is the grouping of timbers within the sampled material. Inspection of *in situ* timbers may indicate that samples derive from a common timber, while common arrangements of anatomical features (knots & branching) may also indicate that samples are derived from a single tree.

Tree-ring analysis is used to support suggestions of same-tree groups between samples based on a combination of information. Timbers derived from the same tree are generally expected to have t -values over 10, although lower t -values may be produced when different radii measured from the same tree are compared. Tree-ring series producing t -values of 10 or above are examined to identify same-tree groups. Good comparisons of visual matching, growth rates, short and longer-term growth patterns, are combined with pith information, sapwood boundaries, bark and anatomical anomalies, to help decide whether timbers are likely to come from the same tree. Where timbers are assessed as deriving from the same tree, to avoid bias the series are averaged to produce a single tree-ring series before inclusion in the final site chronology, but inevitably some same-tree samples go undetected by dendrochronology.

Chronology Building and Cross-dating

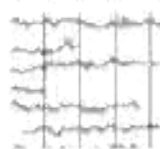

The process of cross-matching compares all tree-ring series against one another and those found to cross-match satisfactorily together are combined to create an average series. The site mean(s) and individual ring series which remain unmatched with the site mean are then tested against a range of established reference series (reference chronologies). Significant t -values replicated against a range of series at the same position with satisfactory visual matching are similarly used to establish cross-matches with reference chronologies. Where cross-matching is established against dated reference chronologies, calendar dates can be assigned to the site series. The dates of the first and last rings of dated series are produced as date spans and these dates should not be confused with felling dates. Timbers derived from the same tree are generally expected to have t -values over 10, although lower t -values may be produced when different radii measured from the same tree are compared. Where timbers derive from the same tree, to avoid bias the series are averaged to produce a single tree-ring series before inclusion in the final site chronology.



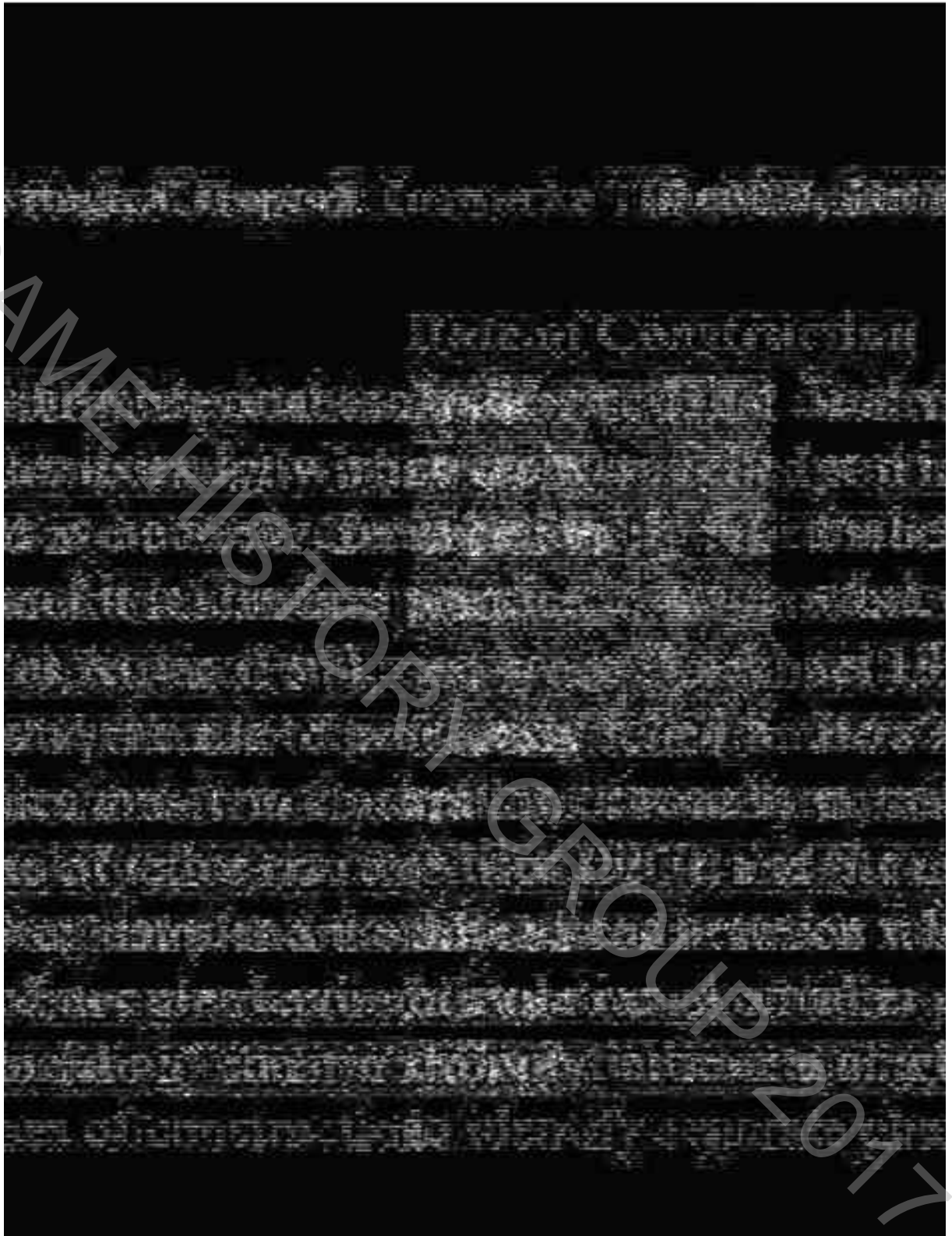

RESULTS

Four sections cut from three timbers were sent for analysis on the 7th February 2011. Sampling locations are indicated on a sketch plan of the building (see Appendix I). Parts of the four sections after sanding to reveal tree-rings are shown below.

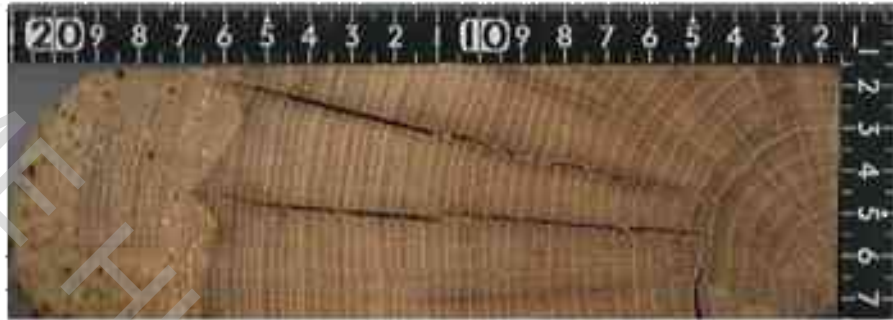

Photo 4: Section of oak from the east end of Beam 6 (series INM101A)



Photo 5: Section of oak from the west end of Beam 6 (series INM101B)



Photo 6: Section of oak from Joist 4 (series INM102)

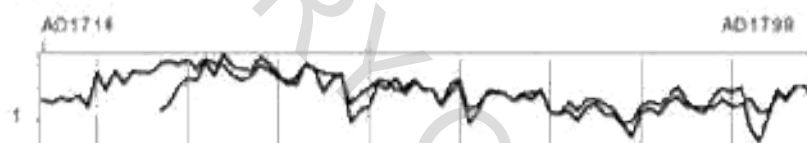

Photo 7: Section of elm from the west end of Beam 7 (Series INM103)

Two samples analysed, INM101 and INM102, were confirmed as Oak (*Quercus* spp), sample INM103 was confirmed to be Elm (*Ulmus* spp). The sections INM101 retained complete sapwood, part of the outer edge of section INM102 extended to the heartwood/sapwood boundary.

Series INM101A and INM101B measured from the sections taken of each end of Beam 6 were found to match together with a t -value of 7.67 and combined to form a mean series INM101.

Figure 3: Plot of site series INM101A and INM101B, which cross-match together with a t -value of 7.67



Note: The ring width (mm) is plotted on a (y axis) logarithmic scale using common axis for both samples.

Series INM101 and INM102 were found to match together with a t -value of 8.66.

Figure 4: Plot of site series INM101 and INM102, which cross-match together with a t -value of 8.66

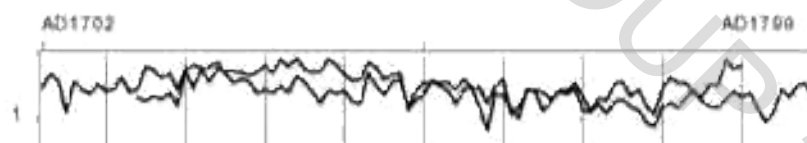

Note: The ring width (mm) is plotted on a (y axis) logarithmic scale using common axis for both samples.

Series INM101 and INM102 were combined to form a 98-year site chronology named MILLB-M1. This site chronology was found to produce consistently high t -values against reference chronologies (Table 3) and to visually cross-match (Figure 3) with the first ring of the series at AD 1702 and the final ring of the series at AD 1799.

Table 1: Dating evidence for series MILLB-MI against reference chronologies

Chronology MILLB-MI dated AD 1702 TO AD 1799					
File	Start Date	End Date	t-value	Overlap (yr.)	Reference chronology
EXETR-CB	AD1898	AD1805	9.15	98	St John's Chapel - Exeter Cathedral - Exeter - Devon (Arnold <i>et al.</i> 2006)
LBC-E	AD1672	AD1763	6.23	92	Leigh Barton - Churchstow - Devon (Groves 2006)
BUCKLAND	AD1677	AD1799	6.18	98	Buckland - Yelverton - Devon (Bridge <i>per comm.</i>)
WINCHSTR	AD1635	AD1972	5.90	98	Winchester - Hampshire (Barefoot 1975)
EXCATH2	AD1662	AD1783	5.86	82	Post-Medieval - Exeter Cathedral - Devon (C Mills unpublished)
ENGLAND	AD404	AD1981	5.37	98	England Master Chronology (Baillie and Pilcher 1982 unpubl.)
EAST_MID	AD882	AD1981	5.23	98	East Midlands (Laxton and Litton 1985)
BSPROOF	AD1705	AD1798	4.33	94	Nave roof - St John's - Bishopstone - Wiltshire (Bridge 1999)
VICTORY	AD1640	AD1800	4.32	98	HMS Victory (Barefoot 1975)
WARWK-MP	AD1746	AD1801	4.13	54	13 Market Place - Warwick - Warwickshire (Moir unpublished)
SHERWOOD	AD1426	AD1981	3.05	98	Sherwood Forest - Nottinghamshire (Briffa <i>et al.</i> 1985)
CSHH09	AD1708	AD1765	3.94	84	Bench at Hungercut Hall - Creeting Saint Mary - Suffolk (Moir 2010)

KEY: Bold - indicates a composite reference chronology consisting of multiple sites chronologies.

Figure 5: Plot of site chronology MILLB-MI (blue) and chronology EXETR-CB from St John's Chapel, Exeter, Devon (black), which cross-match together with a t-value of 9.15

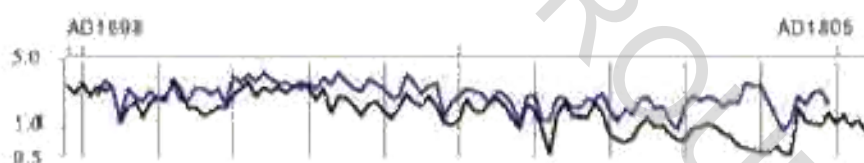

Note: The ring width (mm) is plotted on a (y axis) logarithmic scale using common axis for both samples.

The series INM103 from the section of elm contained rings which were too close together in many parts to be reliably measured.

Dendrochronological Report: Insworke Tide Mill, Millbrook, Cornwall

Table 2: Summary of Dendrochronological Analysis

Sample	Timber and Position	Timber Conversion	Species	Rings	Sapwood	Average Growth Rate (mm/yr)	Sequence Date Range	Felling Date	Rings to Pith	Age Estimate
ENM101	First floor - beam 6	A2	Oak	86	20±0w	2.12	AD1714-AD1756	Winter 1756/60	0	86
ENM102	Ground floor - joist 4	A2	Oak	89	3	2.13	AD1702-AD1790	AD1786-A.5182B	0	86
ENM103	First floor - beam 7	A2	Elm	c. 200		2.38			0	200

KEY						
*	= additional information not measured on the sample					
(t)	= unmeasured heartwood rings at the beginning or end of the sample					
HS	= heartwood/sapwood boundary					
B	= bark (season undetermined)					
3/2B	= spring bark					
5/2B	= summer bark					
Bw	= winter bark					
A2	B2	= boxed heartwood & trimmed	C2	= halved & trimmed		= quartered & trimmed
B2	= boxed heartwood & trimmed					
C2	= halved & trimmed					
	= quartered & trimmed					





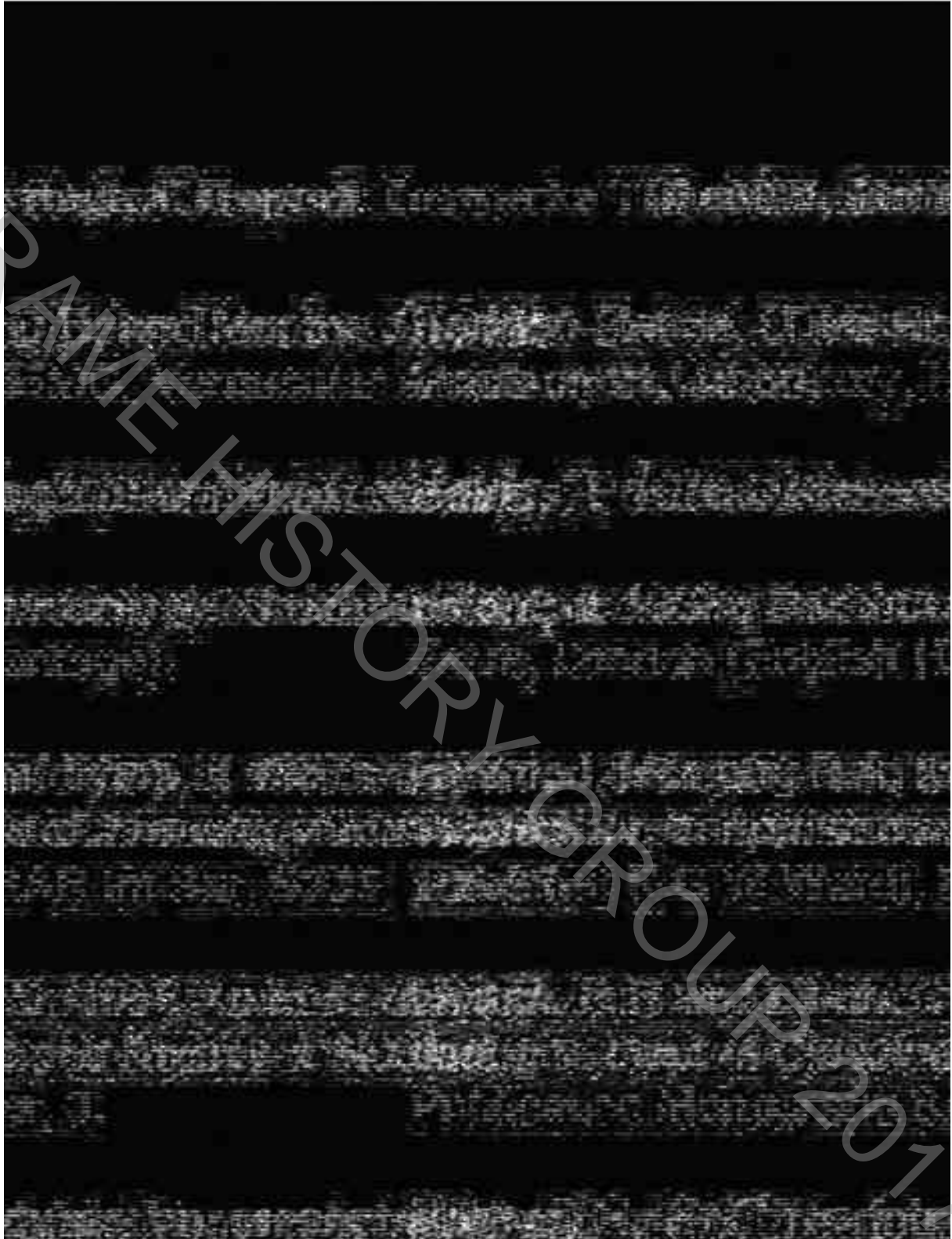

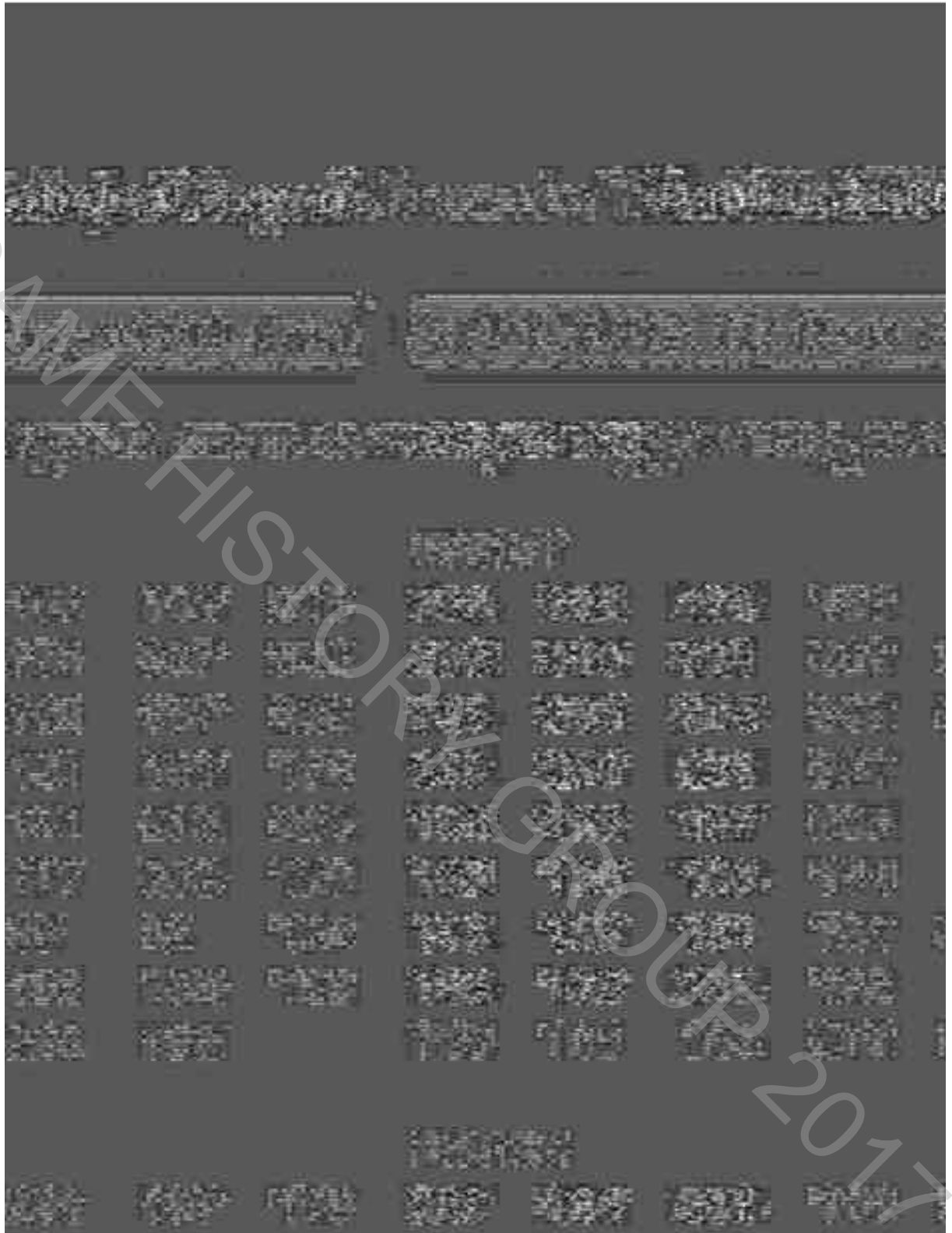

APPENDIX E: North-South Section of Insworke Tide Mill showing the location of samples (not to scale)

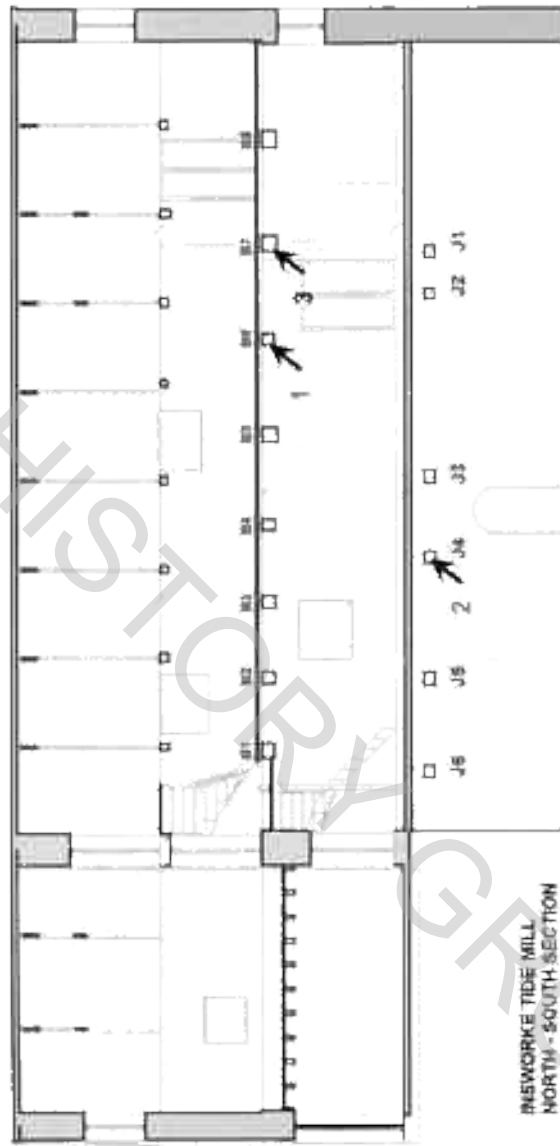

KEY:
Numbers identify location of the cores taken.
Blue = oak dated to AD 1803
Black = Undated elm section

14. DRAWINGS: ELEVATIONS, SECTIONS AND PLANS

14.1 Feature Codes

A – K	Roof trusses
B1 – B8	Timber Beams first floor
D1 – D6	Doorways
F1 – F3	Frames for sluice controls
J1 – J6	Timber Joists ground floor
S1 – S5	Sluice channels and openings
W1 – W13	Windows

14.2 Colour Codes

□	Blue = Water channel
□	Green = timber
□	Grey = Slate stones
□	Pink = Granite
□	Red = Brick

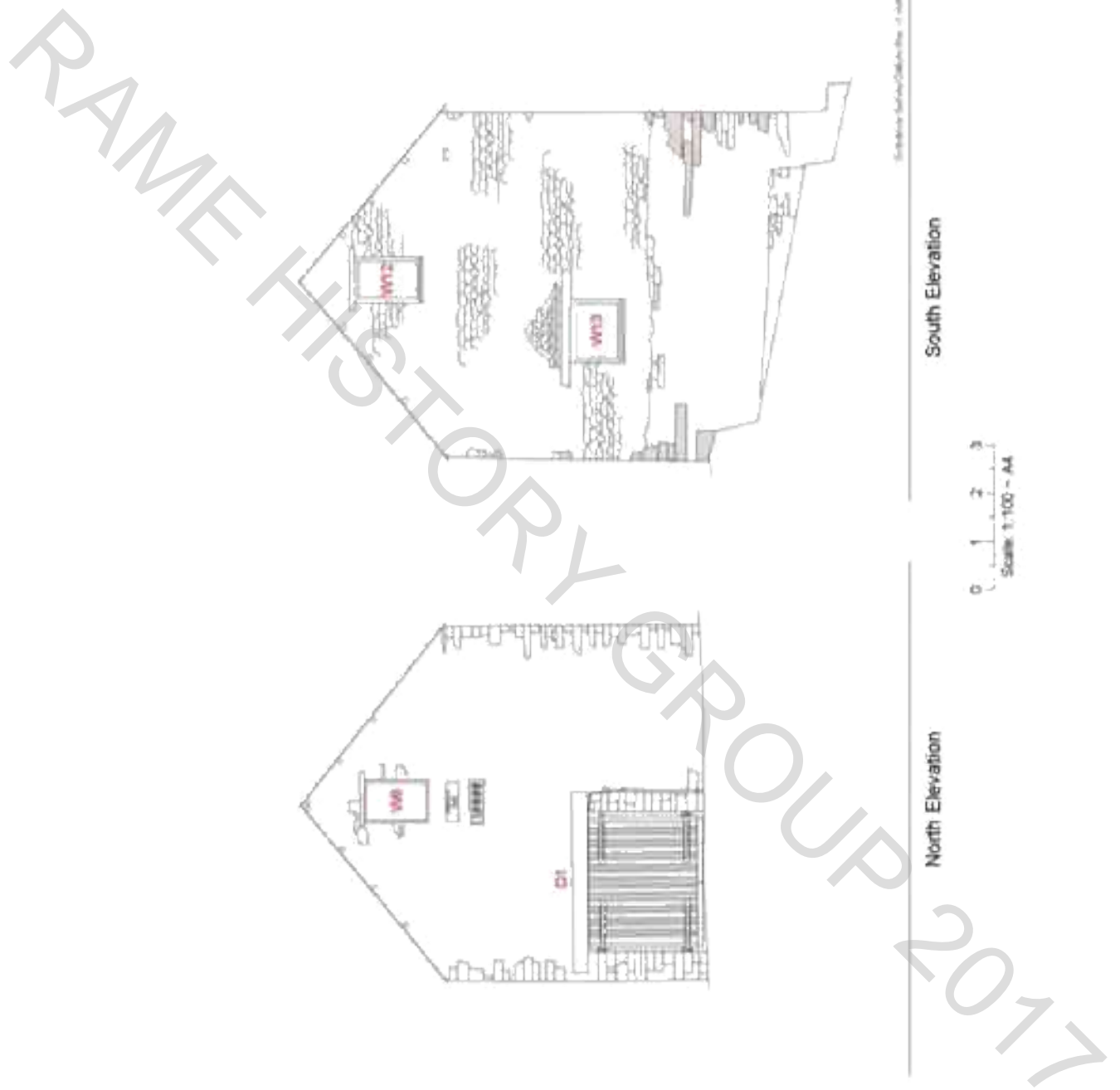

14.3 North and South elevations

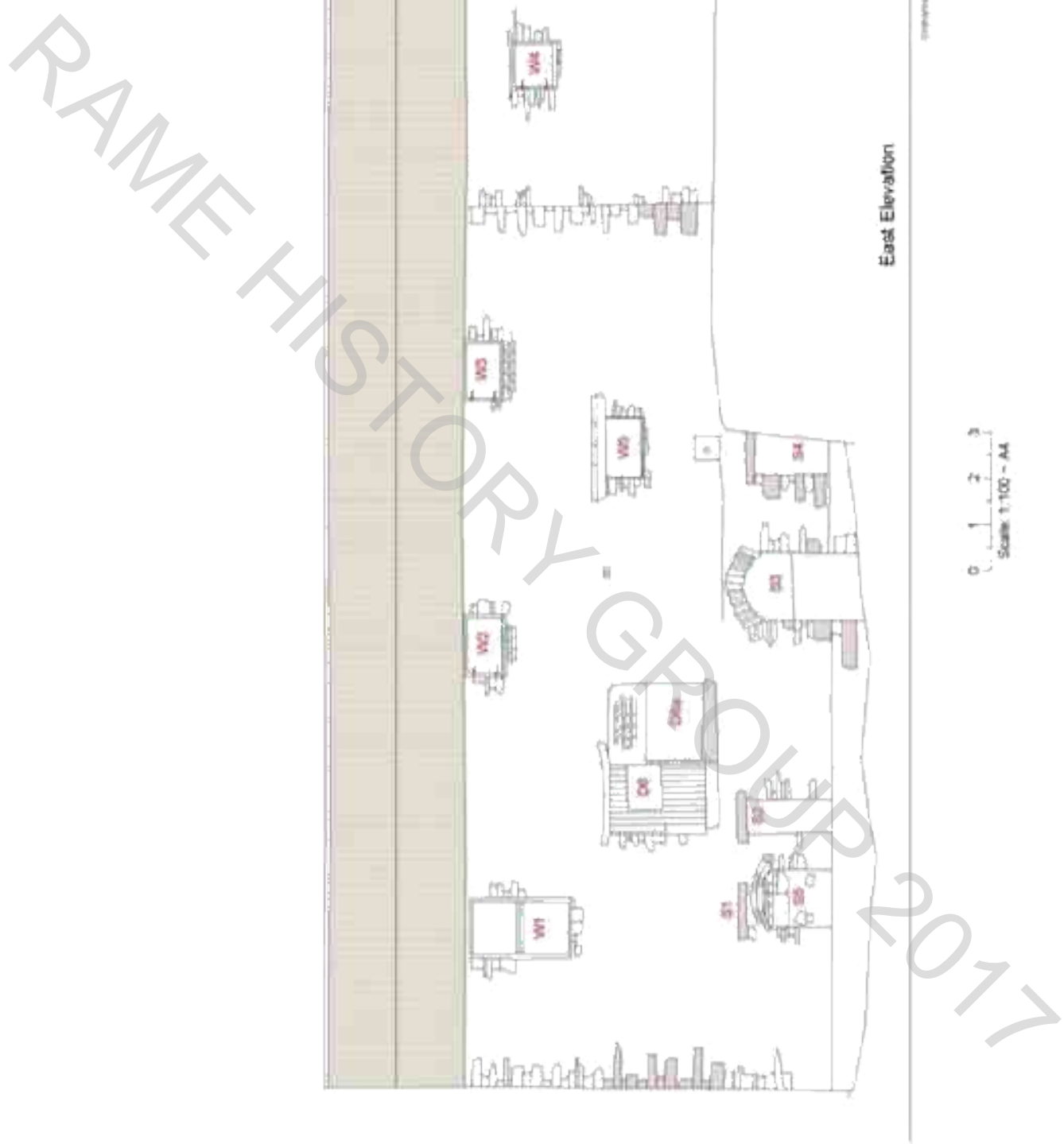

14.4 East Elevation

RAMBOLL HISTORICAL GROUP 2017

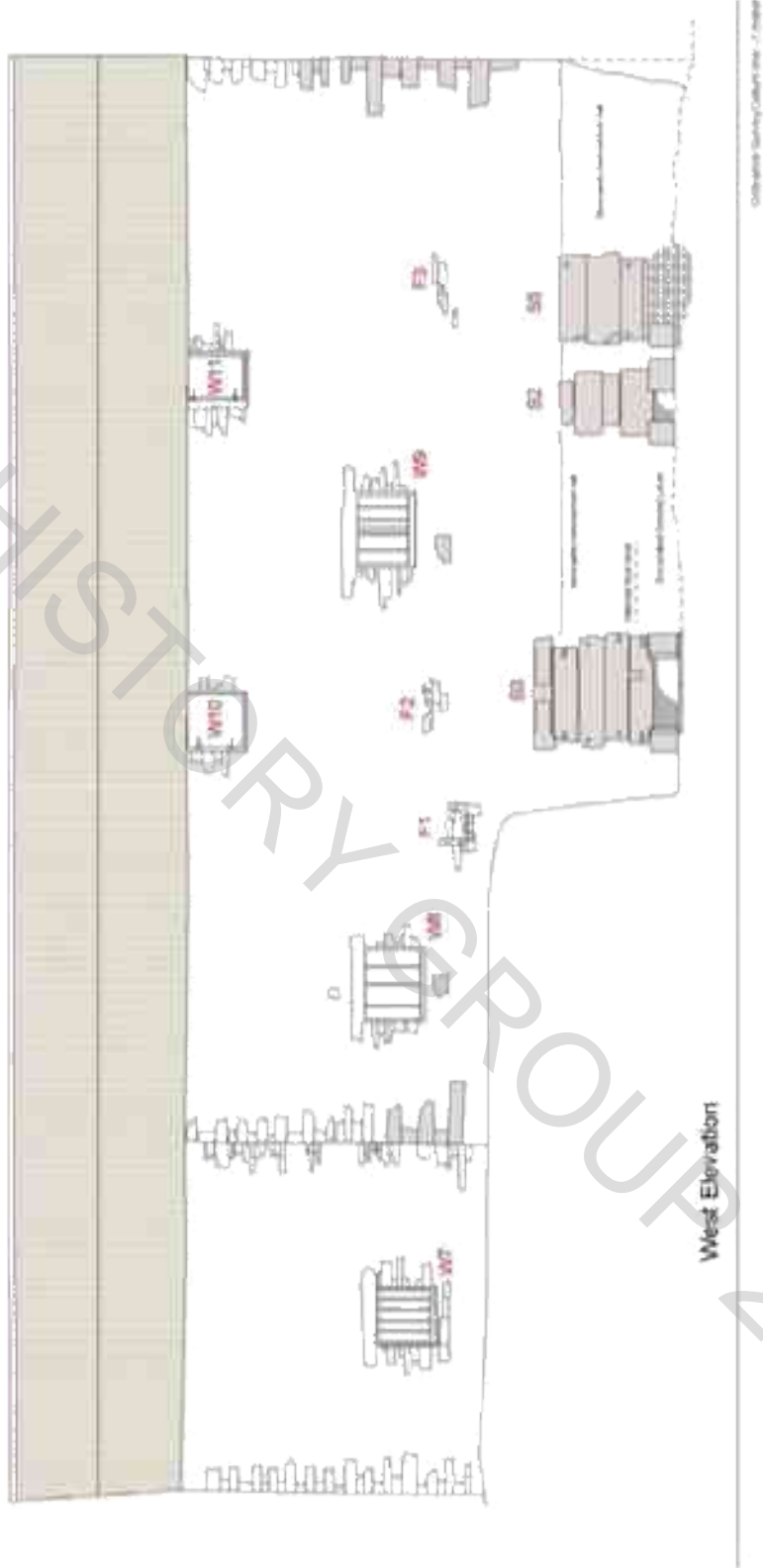

14.5 West Elevation

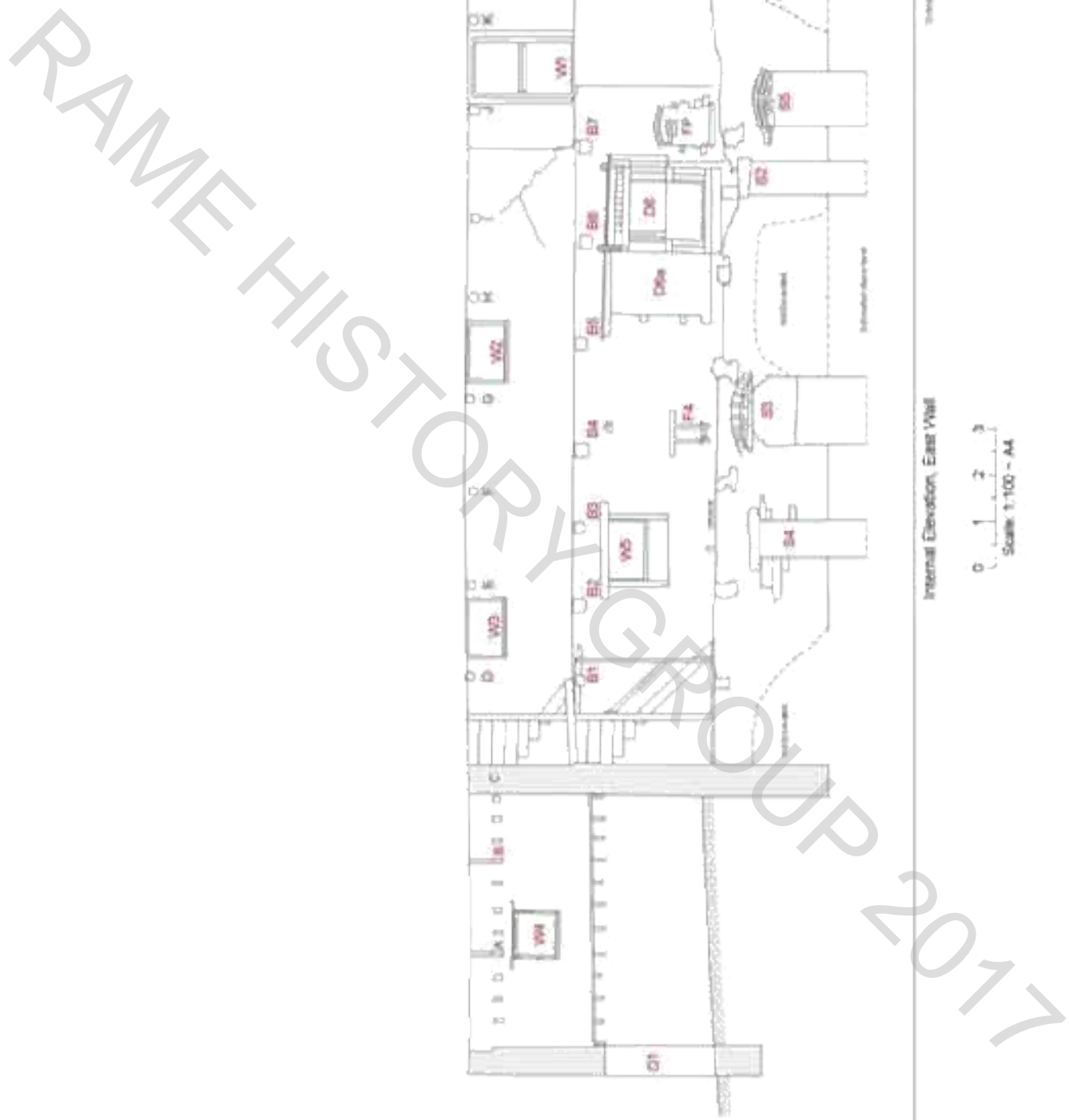

14.6 Internal Elevation east wall

RAME HISTORY GROUP 2017

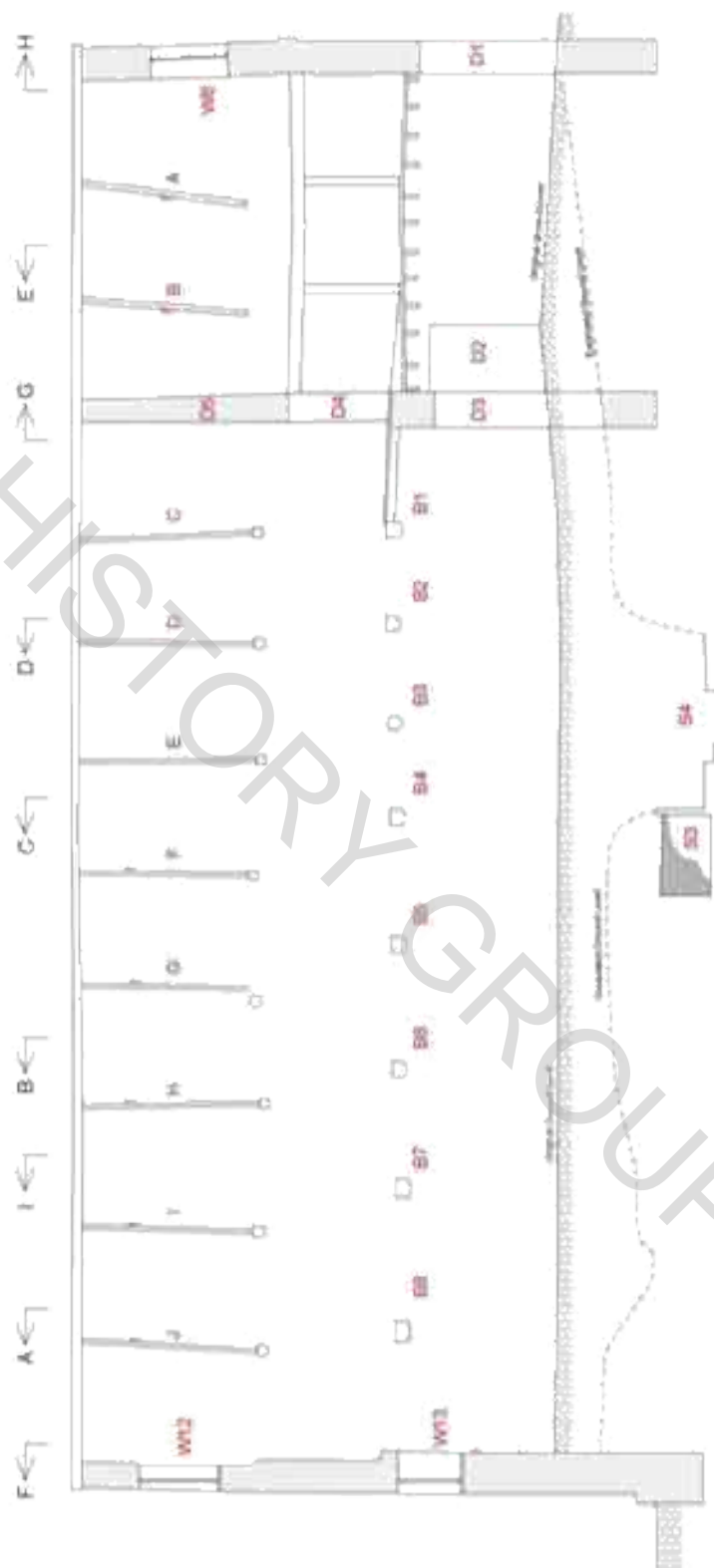

Section F.F

0 1 2 3
Scale 1:100 - A4

14.7 Section looking west

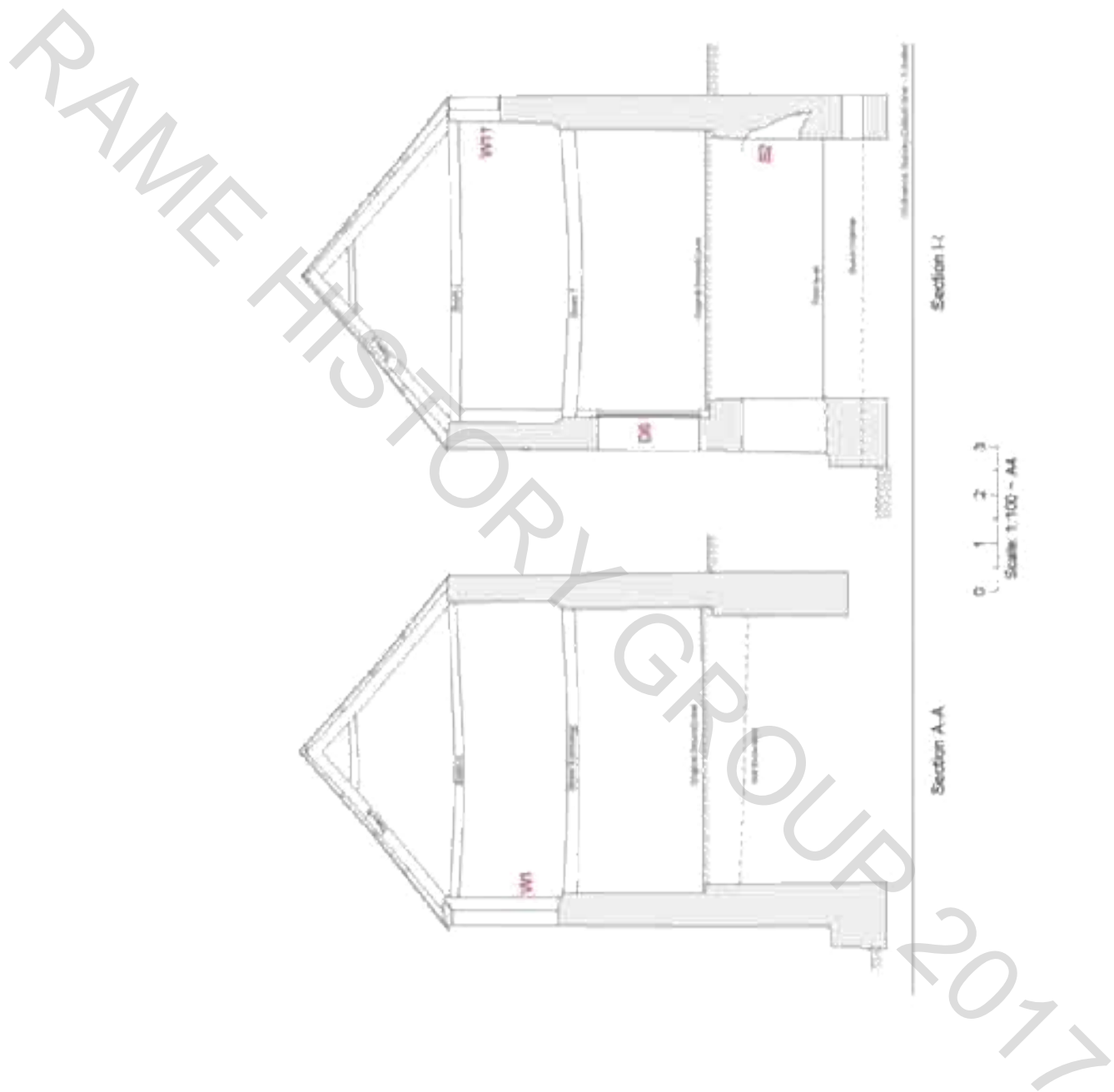

Sections A-A and I-I

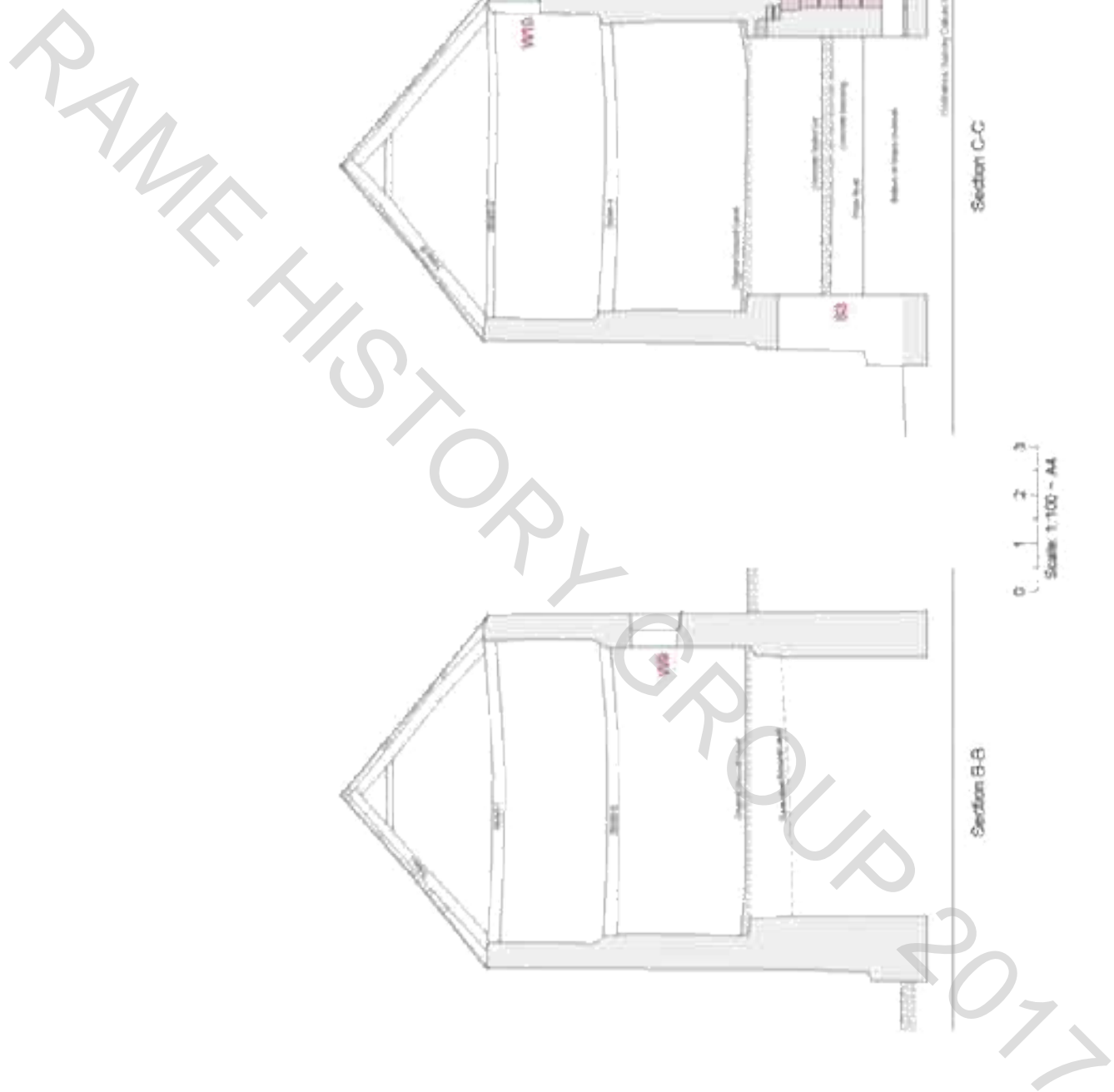

14.8 Sections B-B and C-C

RAME HISTORY GROUP 2017

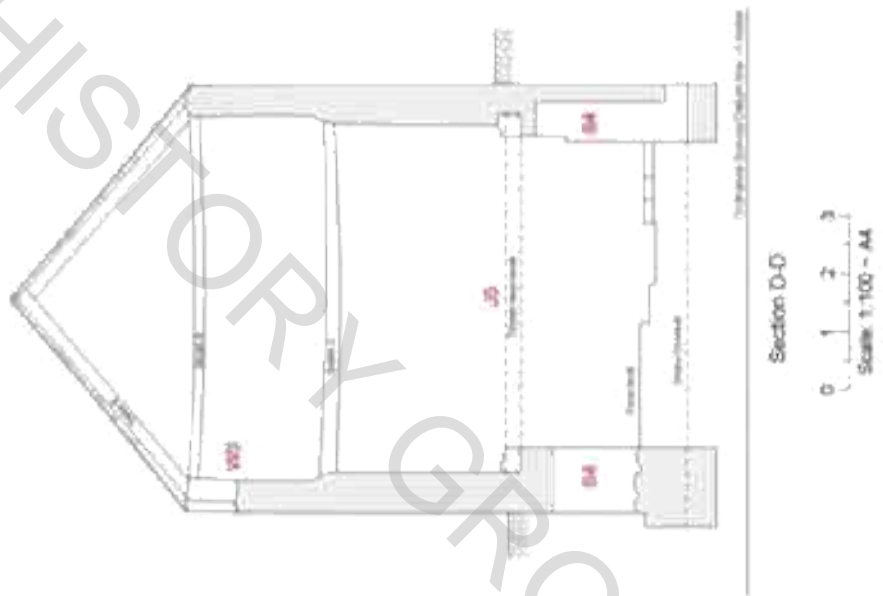

14.8 Section D-D

FRAME HISTORY



© 2017 Jacobs Turner Construction, LLC

Elevation G-G

0 1 2 3
Scale: 1/100 - A4



Section E-E

14.10 Section E-E and Elevation G-G

RAMME HISTORY

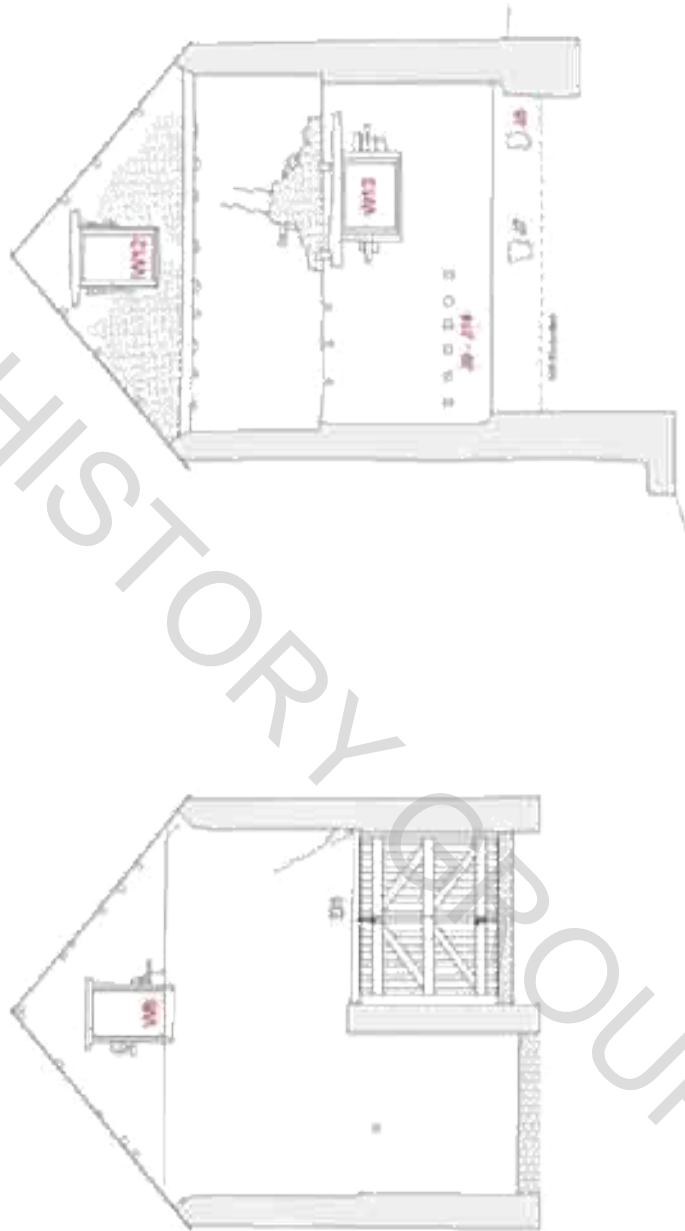

14.11 Elevations H-H and F-F

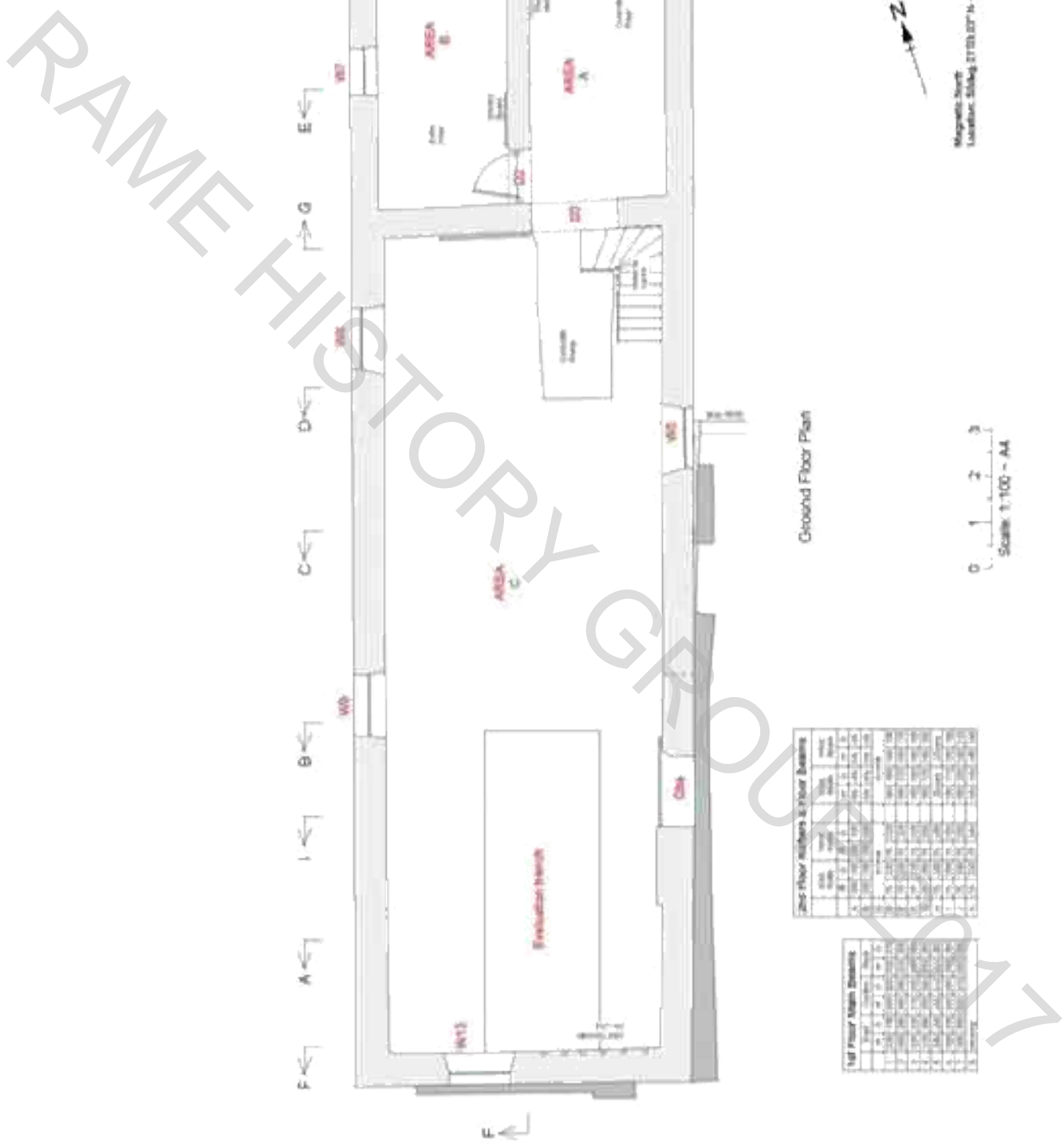

14.12 Ground Floor Plan

RAME HISTORICAL GROUP 2017

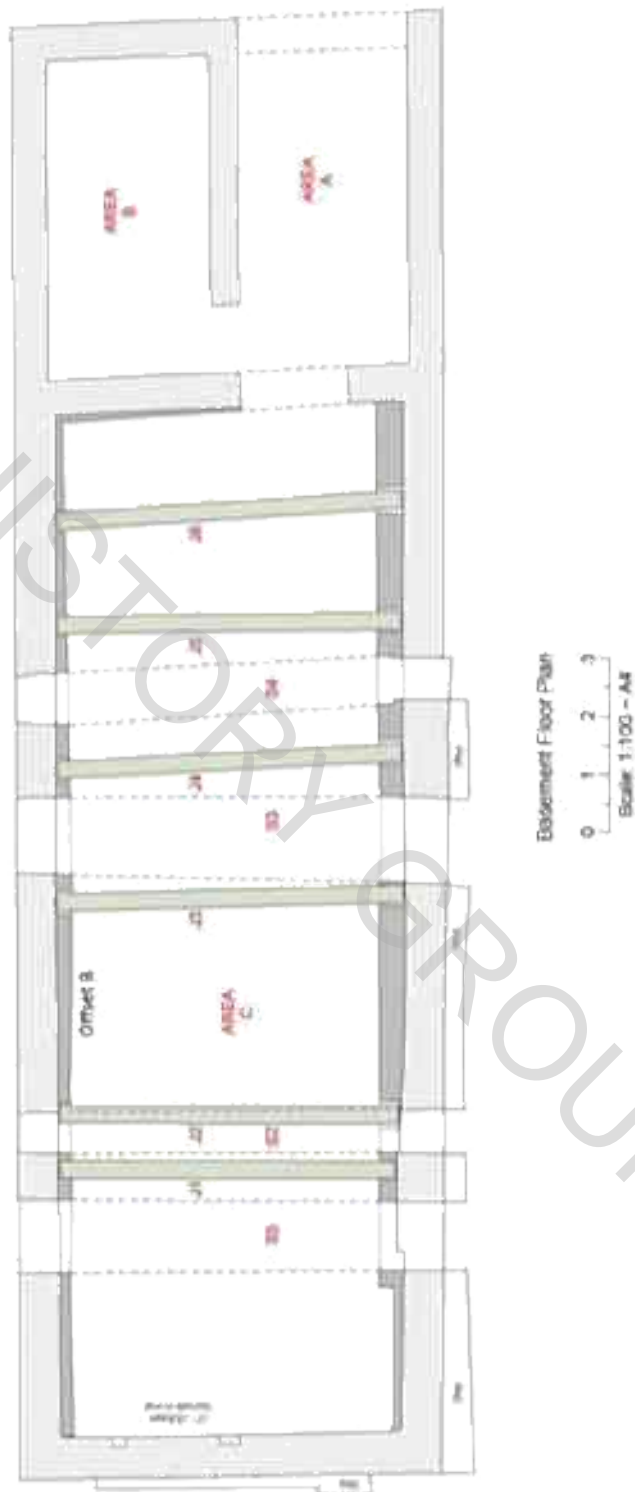

14.13 Basement Floor Plan

RAME HISTORY GROUP 2017

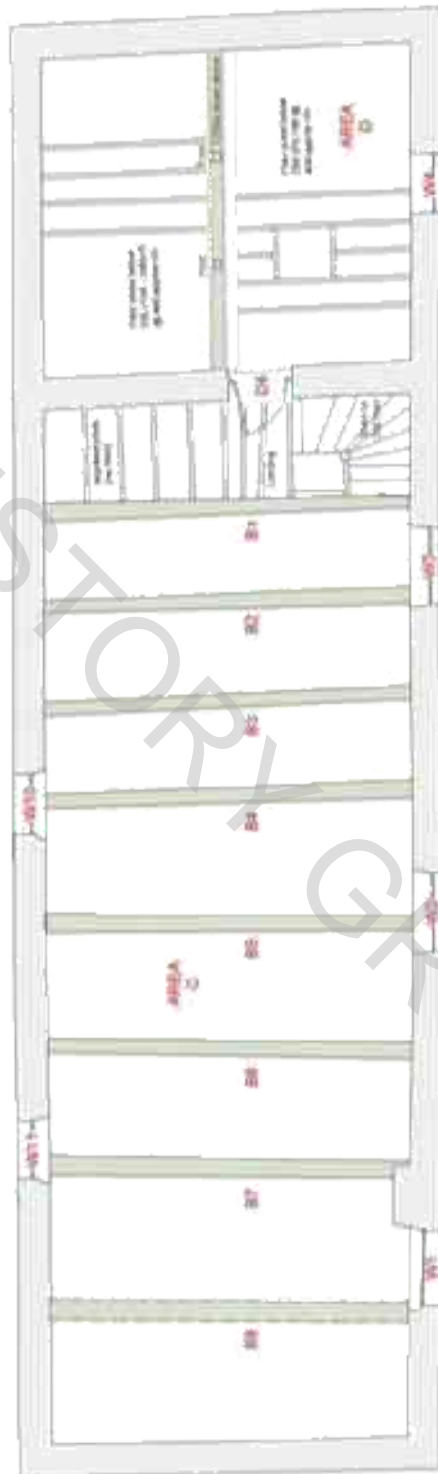

14.14 First Floor Plan

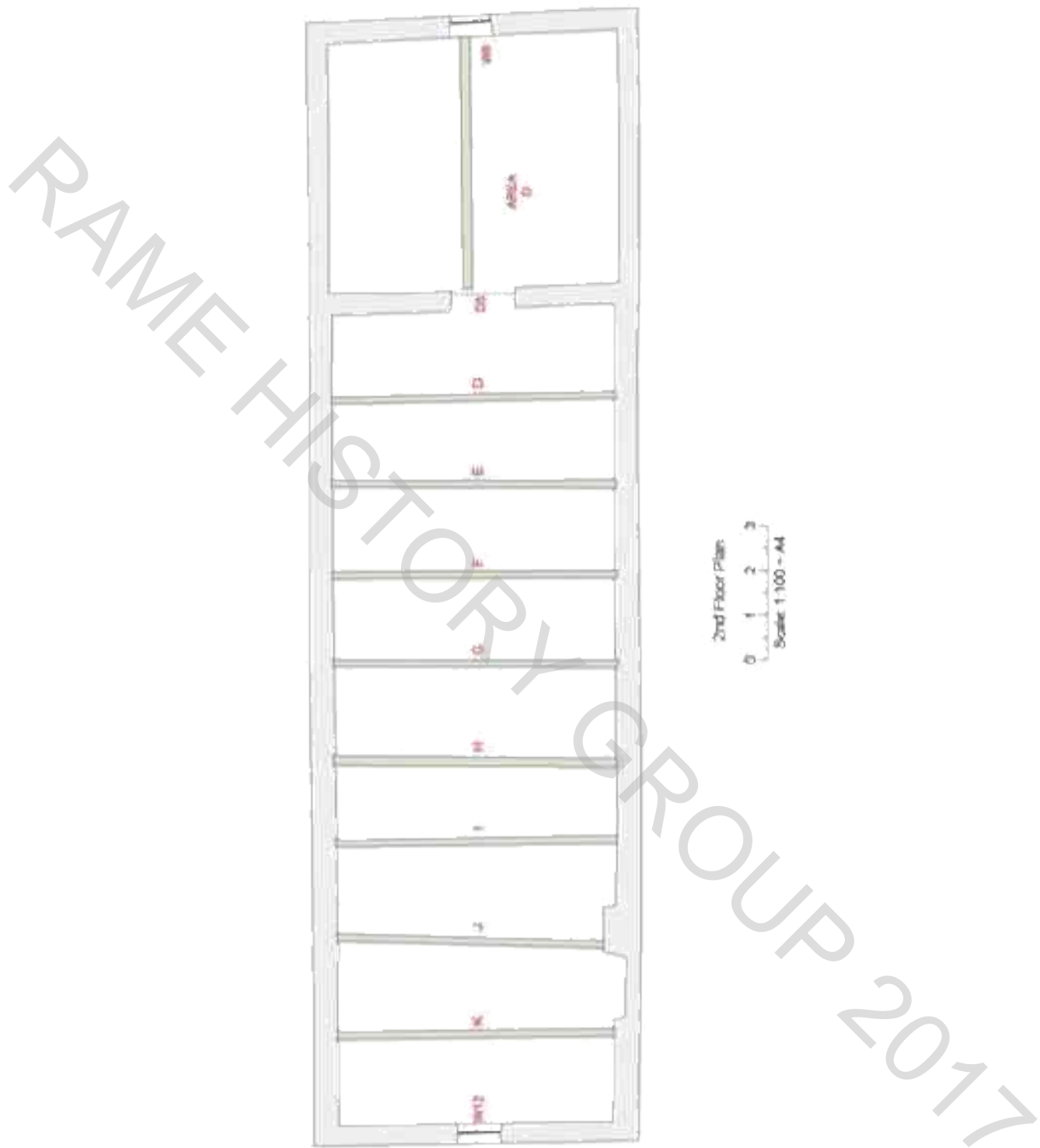

14.15 Second Floor Plan

FRAME HISTORY GROUP 2017

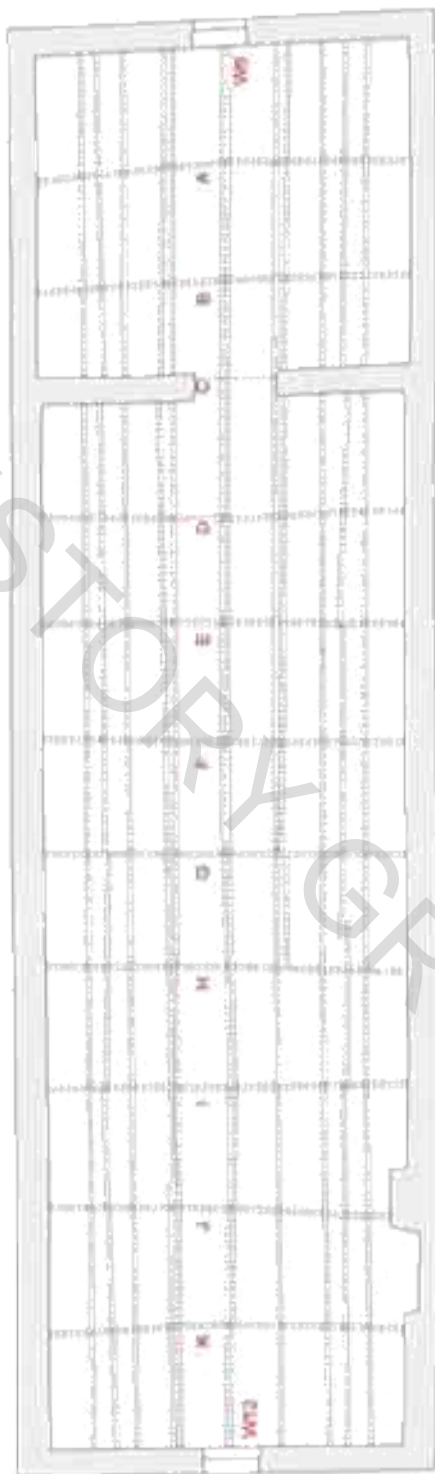

14.16 Roof Plan

15. ARCHAEOLOGICAL DRAWINGS

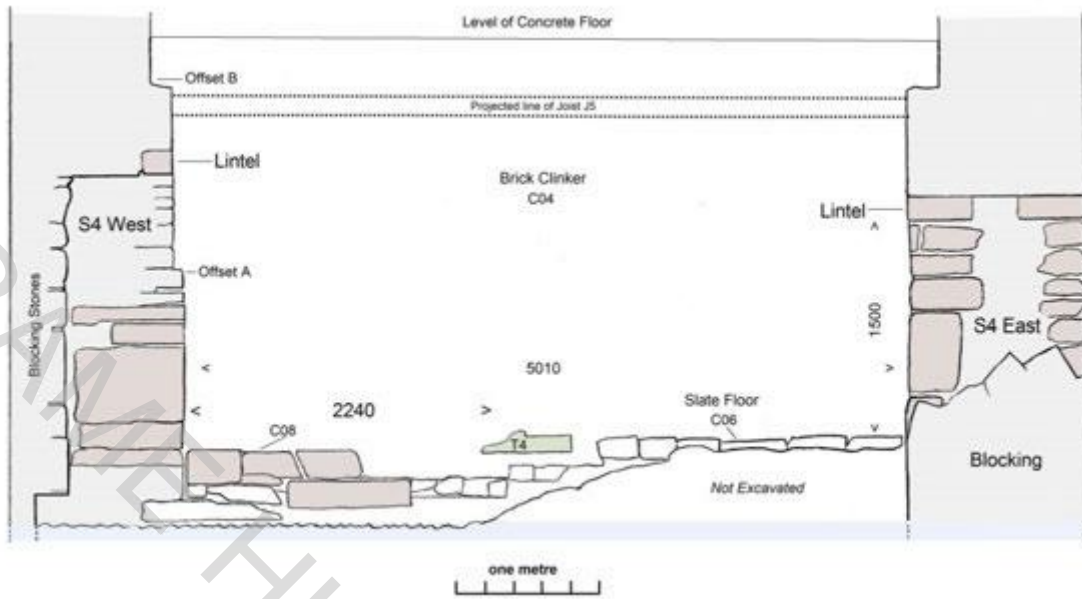

15.1 Basement Section across Sluice S4 looking north

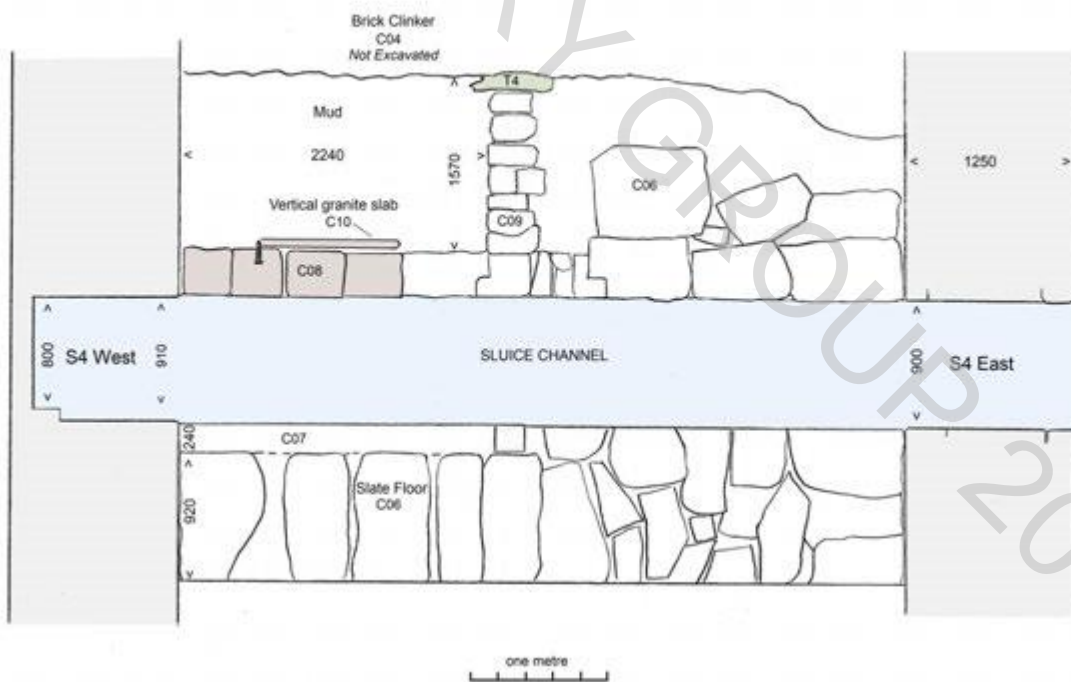

15.2 Basement Plan of Sluice S4

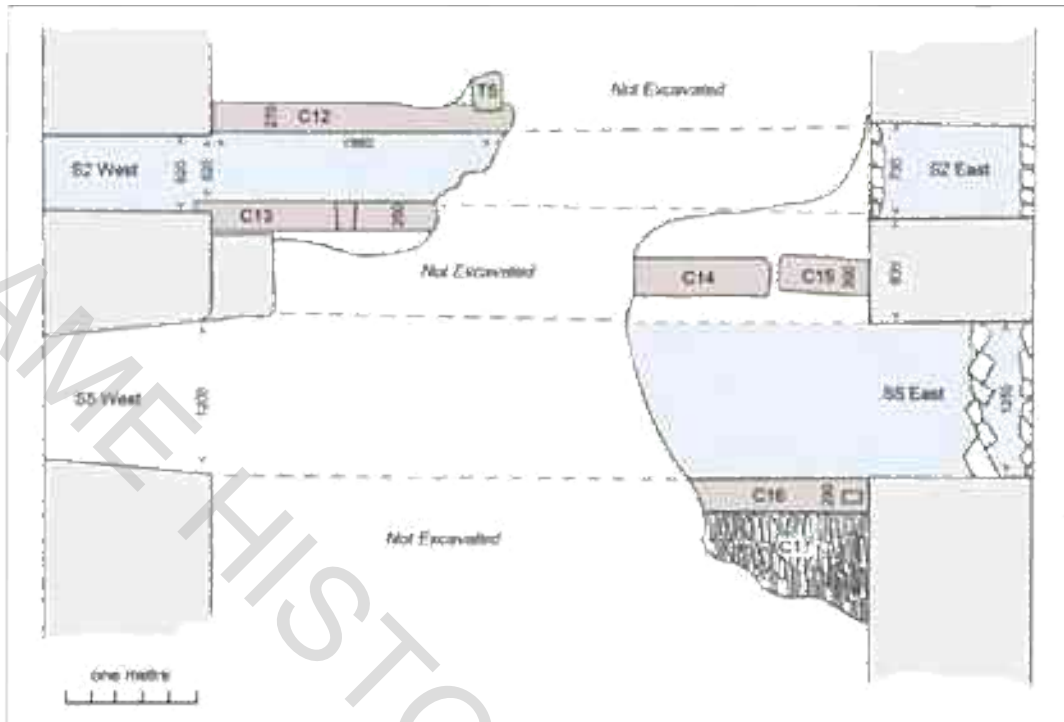

15.3 Basement Plan of Sluices S2 and S5

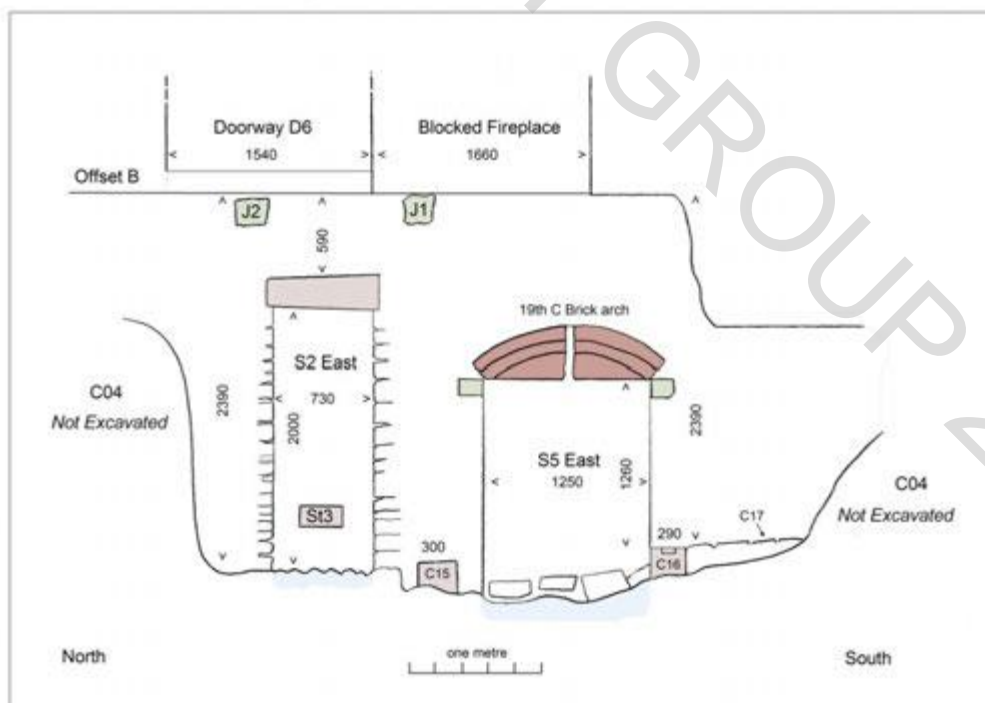

15.4 Basement Elevation of Sluice S2 and S5

RAME CONSULTING GROUP 2017



15.5 Ground Floor Joists and Basement Sluices

RAMIFIED HISTORY GROUP 2017

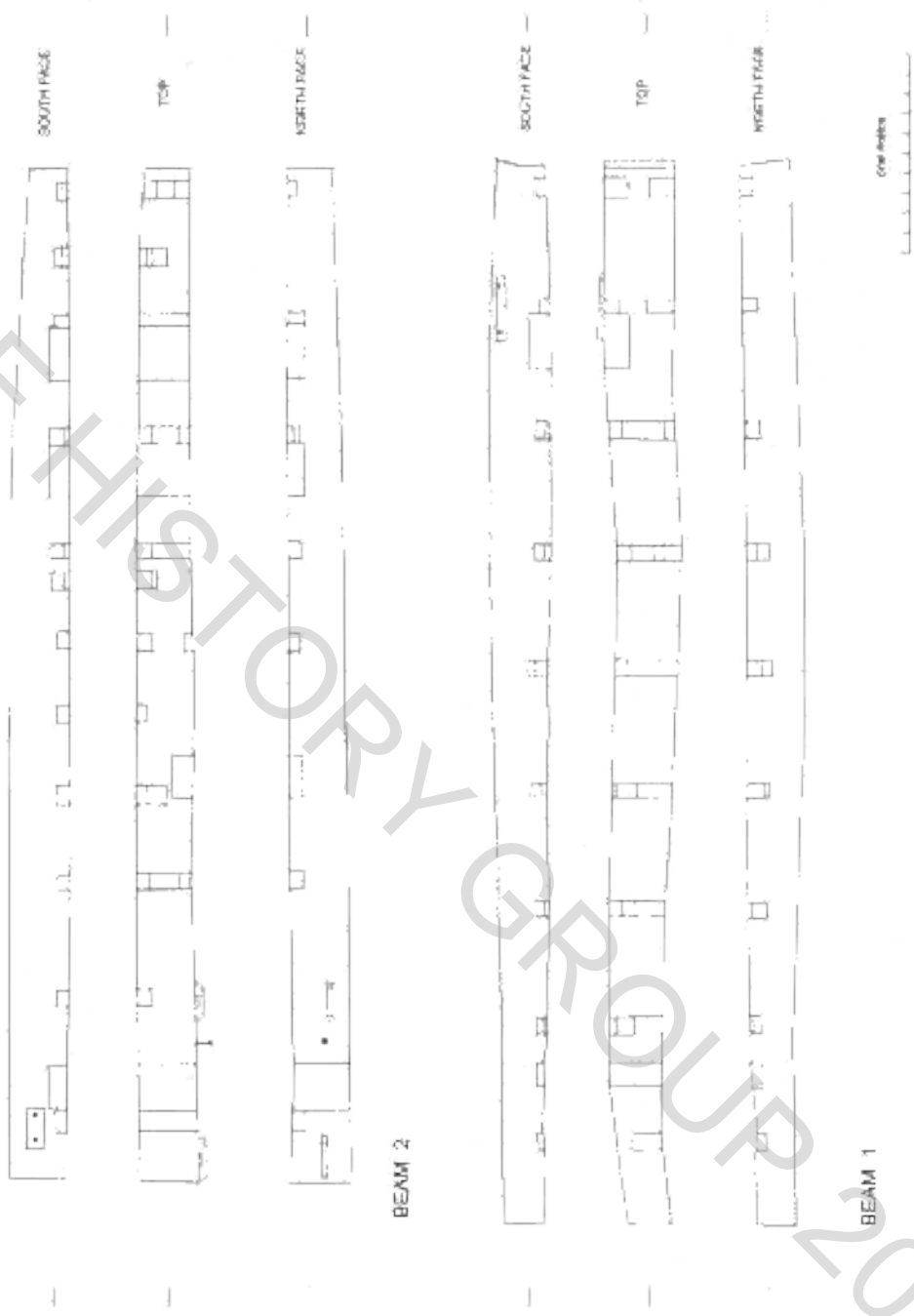

15.6 Beams 1 and 2



15.7 Beams 3 and 4

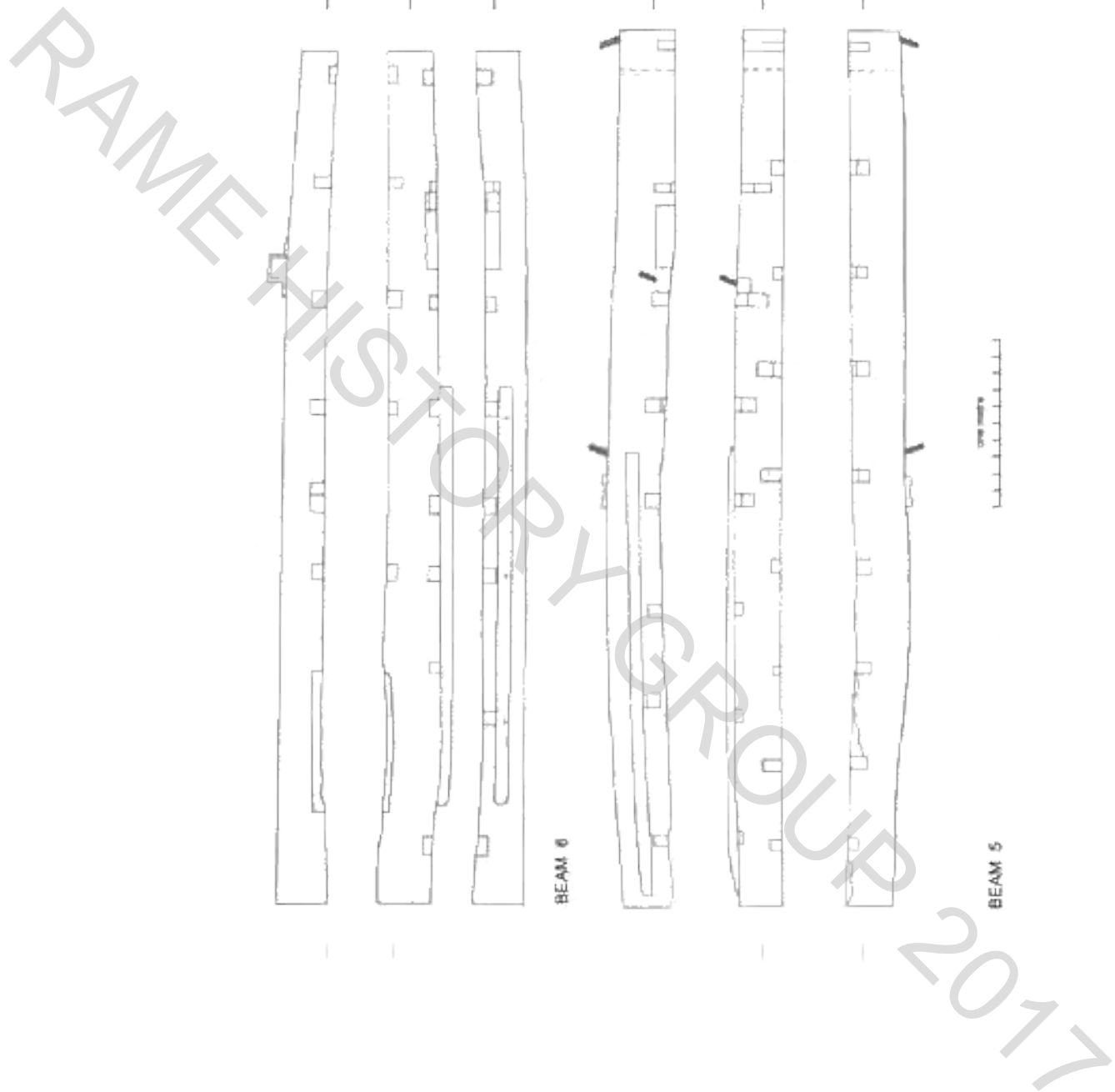

15.8 Beams 5 and 6

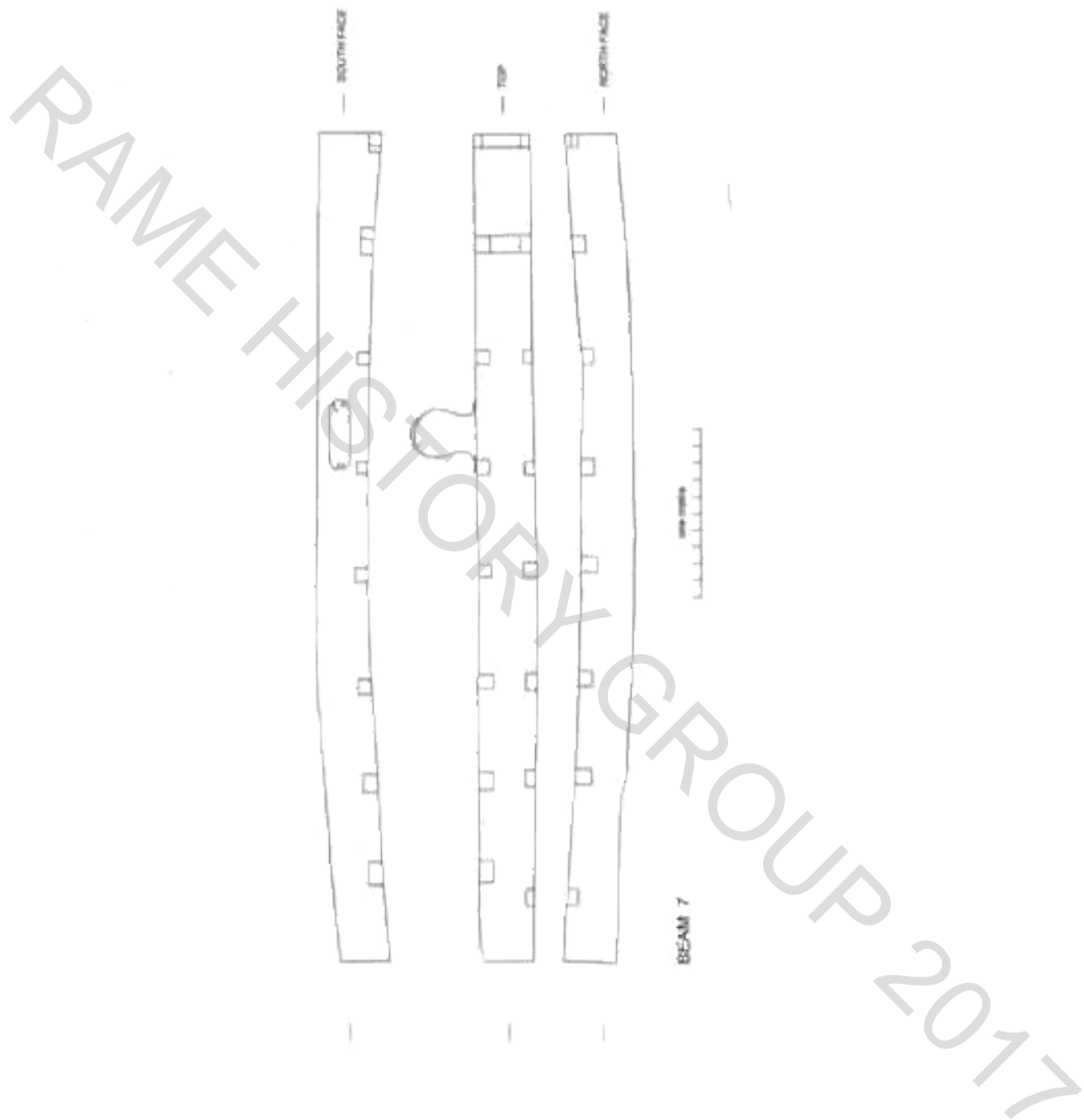

15.9 Beam 7

16. BRIEF FOR HISTORIC BUILDING & ARCHAEOLOGICAL RECORDING

Date: 11 May 2010

Site: Insworke Tide Mill, Millbrook, Torpoint, Cornwall, PL10 1EN

Applicant: Mr Darren Newton, Multimarine Composites Ltd., Foss Quarry, Millbrook, Cornwall, PL10 1EN.

Agent: Mr Carl Newton, C2 Conceptual Design, Kingsway, 10 The Priory, Modbury, Devon, PL21 OTL

Historic Environment Planning Advice Officer: Phil Copleston, Historic Environment Service, Cornwall Council, Room 82, Luxstowe House, Liskeard, Cornwall, PL 14 3DZ Tel. 01579 341406, Email: pcopleston@cornwall.gov.uk

Local Planning Authority Officer: Cheryl Stansbury, Planning and Regeneration, Cornwall Council, Luxstowe House, Liskeard, Cornwall, PL14 3DZ

This brief is only valid for six months. After this period the Historic Environment Planning Advice Officer (HEPAO) should be contacted. Any written scheme of investigation (WSI) resulting from this brief shall only be considered for the same period. The contractor is strongly advised to visit the site before completing their WSI as there may be implications for accurately costing the project.

Contractors Written Scheme of Investigation (WSI) No ground works are to be undertaken until the HEPAO and the Local Planning Authority (LPA) have approved the archaeological contractor's WSI.

1 Introduction

This brief has been written by the HEPAO and sets out the minimum requirements for archaeological recording at Insworke Tide Mill, Millbrook to discharge condition 5 of planning application 09/01932/FUL. The structures are recorded on the Tithe Map of the 1840s, and Ordnance Survey Maps of 1880, 1907 and 1914 etc. Vernacular remains are becoming increasingly rare and are worthy of recording prior to development.

2 Site Location and Description

Insworke Tide Mill is located on the north bank of Millbrook Lake - a sea inlet off the Hamoaze - 600m ENE of Millbrook village on the Rame peninsula in SE Cornwall. The once tidal mill pond inland of the former mill building is now infilled and used as playing fields, whilst the tidal inlet extending west of the mill is now dammed to form an ornamental lake adjacent to Millbrook village. The mill building is centred on Ordnance Survey grid reference SX 42897 52437.

3 Planning Background

Planning application 09/01932/FUL was submitted on the 9 February 2010 and was for the restoration and change of use of Insworke Mill into commercial and non-residential units, a residential dwelling and a holiday let. This application has been approved subject to 18 conditions. Condition 5 states:

The works hereby approved shall not be commenced until the applicant, or their agents or successors in title, has secured the implementation of a programme of archaeological work in accordance with a written scheme of investigation which has been submitted by the applicant and approved in writing by the Local Planning Authority.

The programme shall consist of:

- a) A DESK-BASED ARCHAEOLOGICAL ASSESSMENT (desk-based assessment of historical sources, maps, photos etc.) undertaken prior to any site recording. This may draw upon and update the evidence from the archaeological assessment submitted with the current planning application (Insworke Tide Mill: archaeological report, Cynthia Gaskell Brown, August 2008), should this be necessary.
 - b) INTERNAL AND EXTERNAL BUILDING RECORDING (archive quality photographic and scale drawn record) of the structure, undertaken prior to any conversion works commencing; and
 - c) BURIED ARCHAEOLOGICAL RECORDING of any below ground remains, both within the building (under the modern floor) and adjacent to the building, undertaken prior to or during early phases of construction
-

works. This is likely to consist of a watching brief during lifting of the floor to record locations of wheel pits, recover artefacts or environmental evidence, and selective excavation adjacent to the exterior of the building for the same purpose, or make use of service trenching etc. undertaken as part of the development works.

The above work should be undertaken by an archaeological contractor in accordance with an approved Written Scheme of Investigation (WSI); it is recommended that a qualified millwright be consulted and inform both the on-site recording and post-fieldwork analysis and report writing phases of the work.

Reason: The works are located in an area of archaeological significance where the recording of archaeological remains should be carried out prior to works taking place in accordance with Saved Policy EV1 of the Caradon Local Plan 1999.

4 Historic Building / Structure Background

Date-stone evidence suggests that the mill was originally built in 1598 and partly re-built in 1801. The lower part of the mill from the river bed up to the ground floor probably dates to the earlier period. A number of blocked or part-blocked tunnels or wheel race outlets (at least 5) are visible on the east side of the foundations. The roof trusses are fixed at the apex with trenails (wooden pegs) and may date from the early 19th century rebuild. The first floor beams are particularly robust in order to take the weight of the millstones and other framework that supported the waterwheels. The ground floor is of uneven concrete and probably conceals much buried evidence for the positions of wheel pits, wheel bearings and sluice channels. A granite wheel bearing from the mill has been observed lying on the foreshore. As far as is known, no previous archaeological investigation has been undertaken of this site apart from the previous 2008 archaeological assessment (from which the data for this paragraph has been extracted).

5 Archaeological Background

The Cornwall & Isles of Scilly Historic Environment record records 21 known sites of tide mills in Cornwall, most of which are only evidenced by fragmentary physical remains or portions of the tidal dam ('cawsey').

Insworke Mill represents what is probably the last remaining 'unconverted' tide mill building in Cornwall out of the five surviving examples. (The others are at Torpoint, Looe, Antony Passage and St Germans, all previously converted or modified to modern use.) This building therefore represents the last opportunity to archaeologically investigate and record the physical remains of a Cornish tide mill prior to conversion to modern use. Indeed, discussion with

a qualified millwright suggests that Insworke Tide Mill may be of southwest regional importance, as no unconverted examples are known to survive in Devon. Insworke Tide Mill is a Grade 11 Listed building.

An earlier desk-based assessment and site walk-over (Cynthia Gaskell Brown, August 2008) usefully summarises the documentary and visual evidence, but as far as is known no thorough physical archaeological investigation has been carried out on this building.

6 Requirement for Work

6.1 Desk-Based Assessment: A desk-based assessment is required to draw upon existing historical sources, maps, photos etc. to gain an understanding of the site and to inform any subsequent archaeological recording. A recent assessment (Insworke Tide Mill: Archaeological Report, Cynthia Gaskell Brown, August 2008) may provide sufficient information to fill this requirement and adequately inform the recording work, but opportunity should be taken to update this report should further information be available or prove useful.

6.2 Building Recording: The present proposals will culminate in the potential destruction or substantial alteration of the material remains of Insworke Mill. It is therefore important that the site is recorded to an appropriate level; and that the results are made available to interested parties. In this particular instance, for the photographic record, the recorder needs to consider:

- Site layout and organisation
- Function
- Materials, method of construction
- Fenestration
- Internal arrangements
- Original fixtures and fittings
- Subsequent fixtures and fittings
- Evidence of use and status
- Date/period of initial build and subsequent alterations.

In addition during the building recording, the recorder may wish to identify and make recommendations for the sampling of building materials to be taken during archaeological recording (see 6.3 below, last bullet point), such as the dendro-chronological sampling of timbers.

6.3 Archaeological Recording: Ground works associated with the development may disturb buried archaeological remains. It is therefore important that a suitably qualified archaeologist(s) is/are present during these works in order to identify and record any features of interest.

The site specific aims are to:

- Establish the presence/absence of archaeological remains
- Determine the extent, condition, nature, character, date and significance of any archaeological remains encountered
- Establish the nature of the activity on the site
- Identify any artefacts relating to the occupation or use of the site
- Provide further information on the archaeology of Insworke Tide Mill from any archaeological remains encountered
- Date and understand the significance of the site by the sampling of environmental evidence or organic remains, and the recovery of timber samples for dendro-chronological dating

In addition, it is advised that a suitably qualified Millwright be consulted at appropriate stages during the recording, analysis and report writing of this mill, to inform the understanding and significance of the archaeological and historical evidence.

7 General Methodology

7.1 All stages of the investigation shall be supported by a written scheme of investigation (WSI).

7.2 The archaeological contractor is expected to follow the code of the Institute for Archaeologists (IfA).

7.3 Details including the name, qualifications and experience of the site director and all other personnel (including specialist staff) shall be included within the WSI.

7.4 All of the latest Health and Safety guidelines shall be followed on site.

7.5 The IfA's Standards and Guidance should be used for additional guidance in the production of the WSI, the content of the report and the general execution of the project.

7.6 Terminology will be consistent with the English Heritage Thesaurus.

8 Building Recording Methodology

8.1 Prior to the commencement of on site works the historic building contractor should familiarise themselves with the site by examining the information held by the Cornwall and Scilly Historic Environment Record (HER), the Cornwall records Office at Truro and the Cornwall Centre at Redruth, where appropriate.

8.2 Details of how all buildings and structures are surveyed and recorded shall be provided. The site plan will be tied to the national grid.

8.3 The photographic record shall be a comprehensive record to archive standard of the existing buildings and structures. This should include both external and internal coverage with black and white prints and negatives. Colour photography may be utilised for general shots and where it is appropriate for detail shots (negatives and where appropriate CD shall be included in the archive). For both general and specific photographs, a photographic scale shall be included. The photographic record shall be accompanied by a photographic register detailing as a minimum, feature number, location and direction of shot.

9 Archaeological Recording Methodology

9.1 Prior to the commencement of on site works the archaeological contractor should familiarise themselves with the site by examining the information held by the Cornwall and Scilly Historic Environment

record (HER), the Cornwall Records Office at Truro and the Cornwall Centre at Redruth, where appropriate.

9.2 An archaeologist shall be present during all ground works associated with the development, unless circumstances dictate a different approach. A toothless ditching bucket can be used for the removal of any overburden until the first archaeological horizon is exposed. This will then be hand cleaned as appropriate.

9.3 Any surviving remains which will be disturbed or destroyed by the development shall be archaeologically excavated and recorded.

9.4 Details of how all archaeological contexts and artefacts will be excavated, surveyed, recovered and recorded shall be provided. The site will be tied into the national grid.

9.5 Details of the site planning policy shall be given in the WSI. The normal preferred policy for the scale of archaeological site plans is 1:20 and sections 1:10, unless circumstances indicate that other scales would be more appropriate.

9.6 The photographic record shall consist of prints in both black and white and colour together with the negatives. Digital photography may be used for report illustration. For both general and specific photographs, a photographic scale shall be included. In the case of detailed photographs it may be appropriate to include a north arrow. The photographic record shall be accompanied by a photographic register detailing as a minimum, feature number, location and direction of shot.

9.7 If significant archaeological deposits are exposed, all works must cease and a meeting convened with the client and the HEPAO to discuss the most appropriate way forwards.

10 Finds

10.1 All finds, where appropriate, will be retained from each archaeological context excavated.

10.2 All finds, where appropriate, shall be washed.

10.3 All pottery, and other finds, where appropriate, shall be marked with the site code and context number.

10.4 The WSI shall include an agreed list of specialist consultants, who may be required to conserve and/or report on finds, and advise or report on other aspects of the work including environmental sampling.

10.5 The requirements for conservation and storage shall be agreed with the appropriate museum prior to the start of work, and confirmed in writing to the HEPAO.

10.6 Finds work should be to accepted professional standards and adhere to the Institute for Archaeologists Guidelines for Finds Work

10.7 Environmental sampling should be guided by Environmental Archaeology (English Heritage Centre for Archaeological Guidelines. 2001/02).

10.8 Further English Heritage guidance that may be helpful includes Geoarchaeology (2004) and Archaeometallurgy (2001).

10.9 The English Heritage Advisor for Archaeological Science will be able to provide archaeological science advice if required (Vanessa Straker 0117 975 0689).

11 Human Remains

11.1 Any human remains which are encountered must initially be left in situ and reported to the HEPAO and the appropriate authorities (the Coroner), where appropriate. If removal is necessary this must comply with the relevant Government regulations. If burials are encountered their legal status must be ascertained and recording and/or removal must comply with the legal guidelines.

11.2 If human remains are not to be removed their physical security must be ensured, preferably by back filling as soon as possible after recording.

11.3 If human remains are to be removed this must be done with due reverence and in accordance to current best practice and legal requirements. The site must be adequately screened from public view. Once excavated, human remains must not be exposed to public view.

12 Results Building Recording

12.1 The full report including any specialist assessments shall be submitted within a length of time (but not exceeding six months) to be agreed between the applicant and the archaeological contractor, Cornwall Council Historic Environment Service and the Royal Cornwall Museum. A further digital copy shall be supplied on CD-ROM preferably in 'Adobe Acrobat' PDF format.

12.2 The archaeological contractor will undertake the English Heritage/ads online access to the index of archaeological investigations (OASIS).

12.3 This report will be held by the Cornwall and Scilly Historic Environment Record (HER) and made available for public consultation.

12.4 The report must contain:

- A concise non-technical summary of the project results.
- The aims and methods adopted in the course of the investigation.
- A discussion of the archaeological findings in terms of both the site specific aims and the desk based research.
- A location map, a drawing showing those areas examined as part of the recording. All plans shall be tied to the national grid.
- Any specialist reports and assessments.
- A summary of the archive contents and date of deposition.
- A copy of the brief and the approved WSI will be included as an appendix.

12.5 A contingency shall be made within the costs for full publication in an appropriate journal. The HEPAO will notify the contractor of such a need within four weeks of receipt of the report.

13 Results Archaeological Recording

13.1 The full report including all specialist assessments of artefact assemblages shall be submitted within a length of time (but not exceeding six months) to be agreed between the applicant and the archaeological contractor, Cornwall Council Historic Environment Service and the appropriate museum. A further digital copy shall be supplied on CD-ROM preferably in 'Adobe Acrobat' PDF format.

13.2 This report will be held by the Cornwall and Scilly Historic Environment Record and made available for public consultation.

13.3 The report must contain:

- A concise non-technical summary of the project results.
- The aims and methods adopted in the course of the investigation.
- A discussion of the archaeological findings in terms of both the site specific aims and the desk based research.
- A location map, a drawing showing those areas examined as part of the archaeological recording, and copies of any archaeological plans and sections. All plans shall be tied to the national grid.
- All specialist reports and assessments.
- A summary of the archive contents and date of deposition.
- A context register with brief descriptions shall be included as an appendix.
- A copy of the brief and the approved WSI will be included as an appendix.

13.4 A contingency shall be made within the costs for full publication in an appropriate journal. The HEPAO will notify the contractor of such a need within four weeks of the receipt of the report.

14 Archive Deposition

14.1 An ordered and integrated site archive will be prepared in accordance with: Management of Research Projects in the Historic Environment (MoRPHE) English Heritage 2006 upon completion of the project. The requirements for archive storage shall be agreed with the Royal Cornwall Museum.

14.2 If the finds are to remain with the landowner a full copy of the documentary archive shall be housed with the Cornwall Record Office and with the Courtney Library of the Royal Institution of Cornwall.

14.3 The archive including a copy of the written report shall be deposited with the Royal Cornwall Museum within two months of the completion of the full report and confirmed in writing with the HEPAO.

14.4 Where there is only a documentary archive this will be deposited with the Cornwall Record Office as well as the Courtney Library of the Royal Institution of Cornwall.

14.5 A copy of the report will be supplied to the National Monuments Record (NMR) in Swindon.

14.5 A summary of the contents of the archive shall be supplied to the HEPAO.

14.6 Only on completion of 14.1 to 14.5 (inclusive) will there be a recommendation for the discharge of any archaeological recording condition.

15 Monitoring

15.1 The HEPAQ will monitor the work and should be kept regularly informed of progress.

15.2 Notification of the start of work shall be given preferably in writing to the HEPAO at least one week in advance of its commencement.

15.3 Any variations to the WSI shall be agreed with the HEPAO, preferably in writing, prior to them being carried out.

17. WRITTEN SCHEME OF INVESTIGATION

Date: 31 October 2010

Site: Inswork Tide mill, Millbrook, Torpoint, Cornwall, PL10 1EN

Planning Application No: 09/01932/Full. UPRN: 53900313 &00074

Historic Environment Planning Advice Officer (HEPAO): Phil Copleston, Historic Environment Service, Cornwall Council, Room 82, Luxstowe House, Liskeard, Cornwall, PL14 3DZ. Tel 01579 341406. Email: pcopleston@cornwall.gov.uk

Client: Mr Darren Newton, Multimarine Composites Ltd, Foss Quarry, Millbrook Cornwall, PL10 1EN

1. Introduction

1.1 This Written Scheme of Investigation (WSI) has been produced by Cynthia Gaskell Brown at the request of Mr Darren Newton, Multimarine Composites Ltd, Foss Quarry, Millbrook, Cornwall, PL10 1EN.

The proposed programme of works described below is based on the Brief prepared by the Historic Environment Planning Advice Officer of Cornwall Council.

This WSI sets out the scope of works for building recording, archaeological monitoring, excavation and recording of groundworks at Inswork Tide Mill, Millbrook, Cornwall as Condition 5 of Planning Consent granted on application 09/01932/Full for the restoration and change of use of the building.

1.2 Inswork Tide Mill is situated on the edge of Millbrook Lake, (NGR SX42898 52436). It is Listed Grade II; reference number 6/272. The mill building is partly bounded by the tidal waters of Millbrook Lake to the east and south, an infilled tidal mill pond to the west and a public road to the north.

The building is of two main phases with date stones of 1598 and 1801 preserved on the north wall. As a grist mill it was originally powered by at least two waterwheels which were removed along with all the internal machinery probably in the 1940's. In the summer of 2010 unsafe 20th century flooring was removed leaving only the principal roof trusses, floor beams, and staircase in the interior.

1.3 The principle objectives of the programme will be:-

- to prepare a Desk Based Assessment which will inform and justify the building and archaeological recording work at Inswork Mill.
- to investigate and record any historic building fabric or architectural detail that is to be obscured, removed or otherwise affected by the proposed development.
- to monitor groundworks to allow any exposed archaeological deposits to be investigated and recorded.
- to monitor removal of concrete and earth from the interior floor and to carry out an archaeological evaluation to sample survival of structural features and clarify the history of the mill.

2. Preliminary Works

- A desk-based archaeological assessment was prepared by Cynthia Gaskell Brown in August 2008 to support the client's planning application.
- A digital photographic record was made in 2008 by Cynthia Gaskell Brown and supplied to the client
- Further documentary, photographic and cartographic research was carried out between 2008 and 2010 by Cynthia Gaskell Brown as part of a wider local study of milling and industry in the Rame Peninsula. The Client has already been informed of the relevant parts of this work.
- A detailed building survey at a scale of 1:100 was prepared for the Client in August 2010 by Preston Engineering Survey, Lewannick, Launceston. This has incorporated all the features noted in the 2008 Archaeological Assessment and some more recently exposed external features.
- Following a site visit by on 11 October 2010, millwright Martin Watts provided a preliminary sketch of possible below ground features using the 2010 building survey as a guide. This includes comments on likely differences between 16th century and 19th century wheel pit layouts. This has been passed to the Client.

3. Desk Based Assessment.

Prior to excavation work beginning on site the 2008 assessment will be updated and revised to create a Desk Based Assessment. It will include a further review of the County Sites and Monuments Register, 18th century map evidence, a Clinton/Trefusis estate valuation of 1809, historic photographic information, articles in the Cornwall Association of Local Historians Journal and other relevant material.

4. Building Recording

The record will conform broadly to English Heritage Level 2- 3 as set out in *Understanding Buildings: A guide to Good Recording Practice* (English Heritage 2006).

The high quality 2010 measured building survey (see above) will be used as the basis for annotation with feature codes and fuller measured recording particularly of the timber roof trusses, floor beams and evidence for blocked sluice control positions within the walls of the building. The records will note surviving fixtures/ fittings, empty mortises, evidence of use and phasing. This survey is held by the Client as a computer record and can be accessed to provide plans and sections at larger scales so that appropriate additions can be made.

Survey will use tapes, laser and levels and drawn scales of 1:100, 1:20 or 1:10 as appropriate. Information will be added to the 2010 survey as new CAD layers as appropriate with output of final drawings in AutoCAD. Safety considerations may require some timbers to be removed from the building before recording can be completed. Photographs and tagging or marking and listing of such timbers will be done before removal and the timbers stored on site. Brief analysis of the building fabric will be done on site and recorded as notes on record forms or drawings as appropriate.

5 Archaeological Recording

Archaeological work will conform to the relevant guidelines set out by the Institute of Field Archaeologists

5.1 Groundworks Monitoring.

The Client's programme includes opening up a trench outside the mill parallel to the west wall to put electrical services underground and to manage a watercourse as required by Planning Condition Number 6.

This area is part of the Council's recent Land Fill tip. This trench may uncover remnants of sluice channels and wheel pits.

The Client's programme includes reconstruction of the mill pond wall at the south east corner of the mill. This area may provide information about the former sluice gate to the Mill Pond.

Both areas will be opened by a machine and monitored by the site archaeologist. Should archaeological deposits be exposed they will be cleaned and excavated by hand, contexts numbered, recorded and photographed. The trench locations will be tied into the site plan and to the National Grid.

5.2 Monitoring and Excavation of the Interior

The floor of the mill probably conceals evidence for the positions of wheel pits, wheel bearings and sluice channels. Fill may contain parts of waterwheels and gearing as well as rubble. Using the 2010 measured drawings the possible locations for these features will be suggested by the Consultant Millwright before any below ground clearance begins.

Subject to the advice of the Client's Structural Engineer an archaeological evaluation trench will be done initially at the south end of the floor. This is likely to consist of a defined area c. 2.5 metre wide by c.4 metres long at right angles to the south wall. Concrete will be removed by machine and work continued by hand as appropriate. The trench location will be tied into the building survey.

Contexts will be coded, recorded on context sheets and drawn and photographed in situ where appropriate. Survey drawings of below ground structures will be related to the building record. Survey will use tapes, laser and level and drawn scales of 1:100, 1:20 or 1:10 as appropriate to the complexity of the deposit/ feature. Monitoring and recording will be done as the rest of the floor is cleared for restoration with detailed excavation as appropriate.

Trenches in the interior of the mill are likely to be affected by tidal flow and partially flooded.

6. Finds

Excavated finds will be coded, catalogued, washed and marked as appropriate. Spoil will be monitored for recovery of artefacts. Artefacts relevant to the Tide Mill such as millstones and stone bearings collected locally will be catalogued and recorded.

Provision will be made for the analysis of finds by the site archaeologist and consultant millwright. Advice will be taken from specialists in industrial remains in the case of conservation of large scale items involving metals and organic materials. Other requirements for conservation and storage will be agreed with the Royal Cornwall Museum (Planning Brief section 10.5).

7. Palaeoenvironmental

Should deposits or finds be exposed that contain datable or Palaeoenvironmental elements appropriate sampling and post excavation analysis strategies will be initiated. Advice would be sought from the English Heritage Advisor for Archaeological Science (Planning Brief section 10.9)

8. Human remains.

Should any human remains be exposed these will be initially left in-situ, covered and protected until arrangements for their removal, under appropriate Ministry of Justice and environmental health regulations and in compliance with the relevant primary legislation, are organised (Planning Brief section 11.1)

9. Treasure.

Should any finds identified as treasure or potential treasure be exposed, these will be removed to a safe place and reported to the local coroner according to the procedures relating to the Treasure Act 1996 Code of Practice (2nd Revision). Where removal cannot be effected on the same working day as the discovery suitable security measures will be taken to protect the finds from theft.

10. Photographic Record

A photographic record will be made in black and white 35mm format to archival standards and supplemented by digital photographs. Photographs will include scales and be catalogued appropriately for both the building and archaeological works (Planning Brief Section 8.3 & 9.6)

11. Report and Archive Deposition

11.1 The reporting requirement (Planning Brief sections 12 & 13) will be met on completion of the site work.

11.2 Full Reports will follow the requirements set out in the Brief (Planning Brief sections 12.4 & 13.3) and will be submitted to the HEPAO within six months of completion of the field work. A copy of the Brief prepared by the HEPAO for this work will be included in the report.

The report will be made available as paper copies and on CD. The CD will include the full digital photographic record and electronic drawings. Other paper copies will be sent to Local Archive Offices and Torpoint and Plymouth Libraries, subject to the Client's agreement.

11.3 The site archive will be deposited with the Royal Cornwall Museum, and copies of the archive with the Cornwall Record Office and the Courtney Library of the Royal Institution of Cornwall as appropriate.

Finds will remain with the Client. Some of the artefacts relevant to the history of the mill which will be recorded and interpreted, for example millstones, are the property of the owner of the adjoining Mill House.

The Client is able to incorporate other similar large items and small portable finds into displays within his new offices or as landscaping features. It is likely that the finds will be substantially 19th or 0th century in date and relevant to the industrial history of the Millbrook Lake area. Should it not be feasible to replace the main floor beams back in the mill for safety reasons it is being recommended that they are incorporated within a store building that is part of the planned restoration of the quay areas. It would be inappropriate to ask the Royal Cornwall Museum to undertake the storage of such large scale industrial items or take small finds so far from their origin.

11.4 An online OASIS (Online Access to the Index of Archaeological Investigations) form will be completed in respect of the archaeological work.

11.5 The Client has been advised of the need for a contingency sum for full publication in an appropriate journal (Planning Brief section 13.4). It may also be appropriate to publish this on-line using the Client's or another web site. The Client is interested in virtual reconstruction and other more popular methods of dissemination as part of their educational policies.

12. Project Team

The project team will include:

Cynthia Gaskell Brown, MA, MA, FSA: A professional archaeologist, historian and museum curator. Formerly responsible for rescue archaeology with the Archaeological Survey of Northern Ireland; subsequently Plymouth City Archaeologist and Keeper of Archaeology, Plymouth Museum. Extensive multi-period excavation and publication experience, knowledge of medieval and post-medieval finds, vernacular building surveys and industrial sites. Some relevant local work includes recording of Ludbrook Mill, Devon; water-powered features at Morwellham; 16th century Guest-House, Buckland Abbey, 15th - 19th Century Church House South Tawton. Author of the 2008 Inswick Mill archaeological assessment.

CV attached. Will act as project manager and site archaeologist.

Martin Watts: A professional freelance millwright. A member and former chairman of the Mills Section of the Society for Protection of Ancient Buildings he has wide ranging experience of recording and restoring mills throughout Britain. An acknowledged specialist he is the author of several books on the history and technology of milling.

Keith Bousfield B. ng (Mining): A qualified mining engineer with experience of surveying both underground and surface structures and an expert mountaineer. Will act as general volunteer assistant.

Carl Newton: Company Secretary to Multimarine Ltd; will provide client liaison, practical help on site and supplementary photography; a designer with CAD expertise.

13. Health and Safety

Health and Safety requirements will be observed at all times by any archaeological staff working on site. A Risk Assessment will be carried out in conjunction with the Client and their Structural Engineer. Personal safety briefings will be provided to staff, volunteers and consultants where appropriate.

14. Insurance

The Client has Public Liability Insurance. Cynthia Gaskell Brown will take Employers Liability, Public Liability and Personal Accident cover with Towergate for herself and her volunteers. Martin Watts has his own insurance cover.

15. Monitoring

Monitoring arrangements will be as noted in the Brief (section 15). The HEPAO will be given at least one week's notice of commencement of the fieldwork and will be informed of variations and progress.

16. Conflict with other Conditions and Statutory Protected Species

It is understood from the property owners that the proposed archaeological works will not conflict with any other conditions that have been imposed upon the consent granted or any biodiversity issues as covered by the NERC Act 2006.

18. PROJECT BACKGROUND, AIMS, DESK TOP ASSESSMENT, METHODS

Date: 31 October 2011

18.1 The Main Report (sections 1- 15 above) sets out the results of the archaeological and historic building recording and its interpretation. This section provides the project background, project aims, sources used for the Desk Top Assessment and the procedures used as required by the Planning Brief (section 16 above) and by the Written Statement of Investigation (section 17 above).

18.2 Planning Application No: 09/01932/Full. UPRN: 53900313 &00074

Historic Environment Planning Advice Officer (HEPAO): Phil Copleston, Historic Environment Service, Cornwall Council, Room 82, Luxstowe House, Liskeard, Cornwall, PL14 3DZ. Tel 01579 341406. Email: pcopleston@cornwall.gov.uk

Client: Mr Darren Newton, Multimarine Composites Ltd, Foss Quarry, Millbrook Cornwall, PL10 1EN

18.3 Project background

A Planning application 09/01932/Full was submitted on the 9th February 2010 for the restoration and change of use of Insworke Tide Mill into commercial and non-residential units, a residential dwelling and a holiday let to business and residential use. The planning consent was granted on 26 February 2010 subject to conditions, of which Condition 5 reads: -

No development shall take place within the site until the applicant has secured and implemented a programme of archaeological work in accordance with a written scheme of investigation to be submitted and approved by the Local Planning Authority in consultations with the County Archaeologist.

Reason: To ensure that provision is made to record finds of archaeological interest in accordance with the requirements of PPG16 Archaeology and Planning.

Mr Darren Newton contacted Mrs Cynthia Gaskell Brown to provide an estimate of costs for the required works, which were then agreed. A Brief was provided by the Historic Environment Planning Advice Officer, Phil Copleston, who required that a Written Scheme of Investigation (WSI) was prepared by Cynthia Gaskell Brown. The WSI was subsequently agreed.

18.4 The principle objectives were to establish a greater understanding of the :

Site layout and organisation - Function - Materials - Methods of construction - Fenestration - Internal arrangements - Original fixtures and fittings - Subsequent fixtures and fittings - Evidence of use and status - Date and period of initial build and subsequent alterations.

18.5 The site specific aims of the programme were:-

- to enhance the 2008 Desk Based Assessment to help inform the building and archaeological recording work at Insworke Mill.
- to investigate and record any historic building fabric or architectural detail that was to be obscured, removed or otherwise affected by the proposed development.
- to monitor groundworks to allow any exposed archaeological deposits to be investigated and recorded.
- to monitor removal of concrete and earth from the interior floor and to carry out an archaeological evaluation to sample survival of structural features and clarify the history of the mill.

18.6 Desk Based Assessment 2010-2011

A desk-based archaeological assessment was prepared by Cynthia Gaskell Brown in August 2008 to support the client's planning application. This included a digital photographic record made in 2008 .

A detailed building survey at a scale of 1:100 was prepared for the Client in August 2010 by Preston Engineering Survey, Lewannick, Launceston. This incorporated all the features noted in the 2008 Archaeological Assessment and some more recently exposed external features.

In October 2010, the millwright Martin Watts provided a preliminary sketch of possible below ground features using the 2010 building survey as a guide.

Documentary, photographic and cartographic research carried out between 2008 and 2010 by Cynthia Gaskell Brown as part of a wider local study of milling and industry in the Rame Peninsula was reviewed and incorporated.

In 2010 – 2011 additional sources were consulted and included:-

Archives at Cornwall Record Office, Truro: *online and general indexes ; Trefusis Family Papers*

Archives at Devon County Record Office, Exeter: *online and general indexes; Rolle and Clinton Family Papers*

Archives at West Devon Record Office, Plymouth: *online and general indexes : Devon and Cornwall Deeds*
British Library: *Map collections*

Cornwall Heritage and Environment Record

Local knowledge, personal communications and personal libraries of Cynthia Gaskell Brown and Martin Watts

National Archives: www.nationalarchives.gov.uk

Plymouth Reference Library: *Ordnance Survey map collections; Historic map collections. Newspaper collections – microfiches " Sherborne Mercury".*

Postcard collections: <http://www.st-andrews.ac.uk/library/specialcollections/photographic/>

Rame Peninsula Local Collections:

<http://www.rameheritage.co.uk/> and <http://www.ramehistorygroup.org.uk/>

18.7 Building recording

The record conformed broadly to English Heritage Level 2 - 3 as set out in *Understanding Buildings: A guide to Good Recording Practice* (English Heritage 2006).

The 2010 measured building survey (see above) was used as the basis for annotation with feature codes and fuller measured recording particularly of the timber roof trusses, floor beams and evidence for blocked sluice control positions within the walls of the building. The records noted surviving fixtures/ fittings, empty mortises, evidence of use and phasing. This survey is held by the Client as a computer record and can be accessed to provide plans and sections at larger scales.

Survey used tapes, laser and levels and drawn scales of 1:100, 1:20 or 1:10 as appropriate. Information was added to the 2010 survey as appropriate.

Safety considerations required timbers to be removed from the building. Photography and listing of the timbers was done before removal and the timbers stored on site.

Analysis of the building fabric was done on site and recorded as notes on record forms or drawings as appropriate.

18.8 Archaeological Recording

Archaeological work conformed to the relevant guidelines set out by the Institute of Field Archaeologists.

18.9 Groundworks Monitoring.

The Client's programme included opening up a trench outside the mill parallel to the west wall to put electrical services underground and to manage a watercourse as required by Planning Condition Number 6. This was monitored and recorded.

The Client's programme included reconstruction of the mill pond wall at the south east corner of the mill. Tides limited access to the trenches but the area was recorded photographically.

18.10 Monitoring and Excavation of the Interior

Subject to the advice of the Client's Structural Engineer an archaeological evaluation trench was dug inside the building at the south end of the floor. Contexts were coded, recorded on context sheets and drawn and photographed in situ where appropriate,

Monitoring and recording was done as the rest of the floor as cleared for restoration with detailed excavation as appropriate.

Survey drawings of below ground structures were related to the building record. Survey used tapes, laser and levels and drawn scales of 1:100, 1:20 or 1:10 as appropriate to the complexity of the deposit/ feature.

18.11 Finds Excavated finds were catalogued, washed and marked as appropriate. Spoil was monitored for recovery of artefacts. Artefacts relevant to the Tide Mill such as millstones and stone bearings collected locally were catalogued and recorded.

18.12 The Site archive is deposited with Cornwall Record Office. The owners retained the finds.

18.13 Palaeoenvironmental : there was no Palaeoenvironmental material

18.14 Human remains: there were no human remains

18.15 Treasure : there were no items of treasure trove.

18.16 Photographic record was made on black and white film 35mm format to archival standards and supplemented by digital colour photographs. Photographs included scales and are catalogued appropriately for both the building and archaeological works. The black and white films have been deposited with the site archive. A digital database of the colour photographs has been provided on CD.

18.17 Report and Archive Deposition

The report will be made available as paper copies and on CD. The CD will include the full digital photographic record and electronic drawings. Paper and CD copies will be provided to the Cornwall Heritage Record and the Courtney Library, Truro; and Local Archive Offices and Libraries in Torpoint and Plymouth subject to the Client's agreement.

The site archive will be deposited with the Cornwall Record Office. Finds will remain with the Client. The millstones which have been recorded and interpreted are the property of the owner of the adjoining Mill House. The Client will incorporate large items and small portable finds into displays within his new offices or as part of a storage building that is planned as part of the restoration of the quay areas.

An online OASIS (Online Access to the Index of Archaeological Investigations) form will be completed in respect of the archaeological work.

18.18 Project Team

The project team included:

Cynthia Gaskell Brown, MA, MA, FSA: Project manager and site archaeologist.

Martin Watts: Professional freelance millwright

Keith Bousfield B.Eng (Mining): Volunteer

Carl Newton: Company Secretary to Multimarine Ltd; client liaison, supplementary photography; survey and CAD recording

Mrs Cynthia Gaskell Brown, MA, AMA, FSA

E-mail cgbrown@cgb.eclipse.co.uk

31 October 2011

19. ARCHAEOLOGICAL CONTEXT LIST

Area	Context Number	Description	Thickness
A	A 01	20th century concrete floor. Above A 02	Variable 8-10cms
A	A 02	20th century Tarmac floor. Below A 01	Variable 8-10cms
A	A 03	Silt and sand around timbers T 01 and millstone centre St 02. Below A 03	Variable 5-10cms
C	C 01	Concrete floor covering whole interior with much disturbance from rats and subsidence. Above C 02 and C 05; below C 01	Variable c 10cms
C	C 02	Loose laid brick floor covering much of south half of interior; disturbed towards north end. Below C 01; above C 03	Variable c 5- 8cms
C	C 03	Fine black clinker ash. Below C 02 above C 04	Variable 5-10cms
C	C 04	Red clinker fill from Brickworks. Included some over fired brick fragments, 20th century finds, but no clay pie fragments. General fill to bottom of Evaluation Trench and throughout Basement down to original stone flooring. Timber joists J1 and J2 embedded in C 04. Below C 03	Variable c 2.5 metres
C	C 05	Pit cut through C 04 in Evaluation Trench with fill of builders rubble. Cut C 01; in and above C 04	Variable c 1.75 metres
C	C 05a	Disturbed area at north end between and around timber joists J3 – J6. Mix of clinker, stone and earth with much iron debris - spikes, bars, door fittings and chassis of two vintage charabancs. Cut into C 04 with C 04 below	Not defined due to machine digging and tidal influx
C	C 06	Slate-stone flag flooring of Basement; south of sluice channel S4 ; abuts concrete blocking C 11 of sluice S3. Below C 04	Variable c. 5cms
C	C 07	Recess in edge of floor south of sluice channel S4. Below C 04 next to C 06	See plans for dimensions
C	C 08	Granite Edging stones to south of sluice channel S4	See plans for dimensions
C	C 09	Edging of slate-stone floor north of sluice channel S4. Below C 04 ; abuts C 06 and C 11	See plans for dimensions
C	C 10	Vertically set granite slab edging an un-floored pit; silts in pit probed to c.05 metres. Below C 04; abuts C 08	See plans for dimensions
C	C 11	Concrete blocks in Sluice S3. In and below C 04	See elevations
C	C 12	Granite edging stones to north side of sluice channel S4	See plans and elevations
C	C 13	Granite edging stone south side of sluice channel S2. Below C 04	See plans and elevation
C	C 14	Granite edging stone north side of sluice channel S2. Below C 04	See plans and elevation
C	C 15	Granite edging stone north side of sluice channel S2. Below C 04	See plans and elevation
C	C 16	Granite edging stone south side of sluice channel S5	See plans and elevation
C	C 17	Edge-set slate stone flooring of Basement south of sluice channel S5	See plans and elevation

20. BUILDING FEATURES CONTEXT LIST

Context Code	Area	Wall	Feature Type	Description	Date
A-J	Roof	-	Trusses and tie beams	Timber roof trusses coded north to south. A and B in the Extension are 19th century. C-J in main building have 19th century ridges and purlins added to the original c.1800 trusses which were incised with Roman numerals I-VIII on the north faces.	A and B 19th century. C-J 1800 and 19th century
B1	First Floor	-	Floor beam	Elm beam with open housings for common joists; wooden hasp for rope lead on south face	1800
B2	First Floor	-	Floor beam	Elm beam with open housings for common joists. Recesses on top face for timber structure on upper floor	1800
B3	First Floor	-	Floor beam	Elm beam with open housings for common joists; wooden hasp on north face East end. Recesses on top face for wooden structure on top floor. Sawn off supports for first floor hopper	1800
B4	First Floor	-	Floor beam	Elm beam with open housings for common joists. Sawn off supports for first floor hopper. Grooves on top and south face from pulley ropes.	1800
B5	First Floor	-	Floor beam	Elm beam with open housings for common joists. Three iron hasps, one on the south face, two on the underside used to lift millstones for dressing. Wooden housing for support pillar on underside; strengthening strips on south face.	1800
B6	First Floor	-	Floor beam	Oak beam with open housings for joists. Strengthening strip on north face. Rectangular iron fitting on underside.	Winter 1799-1800
B7	First Floor	-	Floor beam	Elm beam with open housings for common joists. Iron fitting for 20th century stove chimney on south face.	1800
B8	First Floor	-	-	Beam removed in early 20th century	
D1	Ground Floor	A North	Doorway	Doorway into Extension with pair 20th century wooden doors; wooden lintel recycled from a boyard	19th and 20th C
D2	Ground Floor	A West	Doorway	Doorway between ground floor rooms in Extension; recycled 18thC plank and ledge door with original lock and hinges	19th C
D3	Ground Floor	A South	Doorway	Doorway from Extension through north wall of main mill. Original doorway widened in 20thC. Lintels: a recycled timber from mill hursting on north side and 20thC steel joist on south side. Wooden sliding door.	18th and 20thC
D4	First Floor	C North	Doorway	Doorway from extension through north wall of Main mill. Sack ramps on both sides	19th C
D5	Loft	C North	Doorway	Original opening into main mill for bringing in sacks ; modified and partially re-constructed in 19th C when Extension added.	1800 and 19thC
D6	Ground Floor	C East	Doorway	Two period door opening. Original D6a to north with granite doorstep, blocked with stone and	1800/ 19th and 20thC

Context Code	Area	Wall	Feature Type	Description	Date
				brick. Secondary opening to south with sliding wooden door.	
F1	Ground Floor	C West	Sluice Control	Blocked feature for sluice control for Sluice S4. Timber inserts around blocked opening through the wall	1800/ 19thC
F2	Ground Floor	C West	Sluice Control	Blocked feature for sluice control for Sluice S3. Timber inserts around blocked opening through the wall	1800/19thC
F3	Ground Floor	C West	Sluice Control	Blocked feature for sluice control for Sluice S5. Timber inserts around blocked opening through the wall	1800/19thC
J1	Ground Floor	C	Floor Joist	Badly eroded floor joist buried in situ under brick floor in both East and West walls	c1800
J2	Ground Floor	C	Floor Joist	Eroded floor joist buried under brick floor in situ in both East and West walls	c1800
J3	Ground Floor	C	Floor Joist	Eroded principal floor joist buried in situ under brick floor under both East and West walls	c1800
J4	Ground Floor	C	Floor Joist	Oak principal floor joist. In situ in both East and West walls, buried under brick floor. Sampled successfully for tree ring dating	c1800
J5	Ground Floor	C	Floor Joist	Eroded principal floor joist In situ in both East and West walls; buried under brick floor.	c1800
J6	Ground Floor	C	Floor Joist	Eroded principal floor joist buried under brick floor. Removed from walls and left lying on top of clinker fill C04	c1800
S1	Basement	C East & West	Sluice arch	Flat granite lintel on East external wall; opening cut away by Sluice S5 No surviving evidence in West wall	16th C
S2	Basement	C East and West	Sluice arches and channel	Flat granite lintels; opening blocked with dry stone walling in East wall. Curved stone lintel inside West wall. Blocked opening visible in external West wall. Water channel defined by narrow granite slabs in Basement floor	16thC
S3	Basement	C East and West	Sluice arches and water channel	16thC Arch with voussoirs on outside East wall. Flat granite lintel inside East wall, part of 1800 rebuild. West wall lintels inside and out are re-used 16thC window sills. West wall arch blocked with re-used 16thC and 19thC granite slabs. Blocked across width of mill with 20thC concrete blocks	16thC/ c.1800/ 20thC
S4	Basement	C East and West	Sluice arches and water channel	Exterior East wall 16thC flat granite slab lintel. Interior East wall granite slab lintel c1800. Interior West wall 16thC window sill re-used as lintel.	16thC/c.18 0/ 19thC
S5	Basement	C East and West	Sluice arches and water channel	Exterior and interior East wall brick arch cutting through earlier sluice arch S1. West wall remade arch with stone and timber lintels. Blocked from exterior with re-cycled coping slabs. Water channel lined with granite slabs.	19thC
W1	First Floor	C East	Window	Timber lintel concrete sill. Enlarged 20thC	1800/ 20thC

Context Code	Area	Wall	Feature Type	Description	Date
W2	First Floor	C East	Window	Timber lintel, concrete sill. Reduced in height with brick courses	1800/20thC
W3	First Floor	C East	Window	Timber lintel, concrete sill. Reduced in height with brick courses	1800/20thC
W4	First Floor	A East	Window	Timber lintel slate-stone sill	1800/ 20thC
W5	Ground Floor	C East	Window	Timber lintel, concrete sill	1800/20thC
W6	First Floor	C North	Window	Timber lintel, stone sill replacement in old opening	19th/20thC
W7	Ground Floor	A West	Window	Timber lintel, concrete sill	19thC/20thC
W8	Ground Floor	C West	Window	Arched timber lintel concrete sill	1800/20thC
W9	Ground Floor	C West	Window	Timber lintel slate stone sill	1800/20thC
W10	First Floor	C West	Window	Timber lintel concrete sill	1800/20thC
W11	First Floor	C West	Window	Timber lintel concrete sill	1800/20thC
W12	First Floor	C South	Window	Timber lintel, concrete sill replacement in old opening	1800/ 20thC
W13	Ground Floor	C South	Window	Timber lintel, concrete sill replacement in old opening	1800/20thC

RAME HISTORY GROUP 2017